



OPERATION AND MAINTENANCE MANUAL
120V/60HZ



FLURRY

CS6-210

CS6-210-HV



MADE IN
THE USA

IMPORTANT

DO NOT contact the supplier your FLURRY unit was purchased from. Contact COOL-SPACE with all warranty and service issues.

COOL-SPACE CUSTOMER SERVICE



800-557-5716

support@cool-space.com

1.0 INTRODUCTION	1
2.0 UNPACKING YOUR FLURRY	2
3.0 SET-UP OF THE COOL-SPACE UNIT	2
3.1 Connecting the water supply.....	2
3.2 Connecting the electrical supply	3
4.0 OPERATING PROCEDURES	4
4.1 Filling the unit with water	4
4.2 Starting the Pump.....	5
4.3 Starting the Fan	5
5.0 MAINTENANCE AND STORAGE	6
5.1 Removing the cooling media.....	6
5.2 Daily maintenance.....	6
5.3 Periodic maintenance.....	6
5.4 Storage.....	7
6.0 TROUBLESHOOTING/REPAIR.....	8
6.1 Troubleshooting	8
6.2 Troubleshooting Guides.....	9
6.3 Fan Repair Procedures.....	12
6.4 Pump Repair Procedures	13
6.5 Wiring Diagram.....	14
6.6 Technical support	14
7.0 WARRANTY	15
7.1 Warranty Registration	15
7.2 Warranty Parts	15
7.3 Optional Accessories and Replacement Parts.....	15

Due to continuous product innovations, we reserve the right to change product specification without due notice.

SIGNAL WORD DEFINITIONS

 DANGER	DANGER indicates an imminently hazardous situation which, if not avoided, WILL result in death or serious injury.
 WARNING	WARNING indicates a potentially hazardous situation which, if not avoided, COULD result in death or serious injury.
 CAUTION	CAUTION indicates a potentially hazardous situation which, if not avoided, MAY result in minor or moderate injury.
IMPORTANT	IMPORTANT indicates a potentially hazardous situation which, if not avoided, MAY result in property damage.

1.0 INTRODUCTION

COOL-SPACE is a patented and registered Trademark of Hale Industries, Inc. COOL-SPACE Portable Evaporative Coolers are manufactured by

Hale Industries, Inc.
315 N. Madison Street
Fortville, Indiana 46040
USA

The COOL-SPACE FLURRY and FLURRY-HV are compact, self-contained, high-efficiency portable evaporative coolers.

FLURRY

The FLURRY unit is designed to have minimal impact visually and maintain low sound levels to ensure a pleasant ambiance. The FLURRY is uniquely suited for patios, restaurants and other open-air venues.

FLURRY-HV

The FLURRY-HV is designed with high output in mind. Its performance level makes it better suited for industrial and automotive applications.

2.0 UNPACKING YOUR FLURRY

IMPORTANT

Carefully examine the carton for damage before opening. If the carton is damaged notify the shipping company immediately.

- Find the package of (4) casters and remove
- Lay box on its side and carefully open the bottom of the box - DO NOT STAND UPSIDE DOWN
- Install (4) casters
- Stand unit up on casters and remove box



3.0 SET-UP OF THE COOL-SPACE UNIT

The COOL-SPACE FLURRY has been factory tested and is ready to use. The unit should be placed on level ground, and the casters locked to prevent inadvertent movement. Follow instructions below to connect water and electrical supply.

3.1 CONNECTING THE WATER SUPPLY

⚠ CAUTION

Do not connect to any water source where water pressure exceeds 120 psi. This will cause permanent damage to the unit.

The FLURRY comes equipped with a female water source connection. Use a standard garden hose (not provided) to connect the water supply to the cooler.



3.2 CONNECTING THE ELECTRICAL SUPPLY

IMPORTANT

The COOL-SPACE unit should be plugged into a fused or circuit breaker protected 15 amp, 120 volt, and 60 Hz circuit.

All models utilize standard 120-volt power supply. The unit should be plugged into a fused or circuit breaker protected 15 amp, 120 volt, 60 Hz circuit.



Table 1 shows the amperage requirements for the specific models. If an extension cord is required, refer to Table 2 for the proper 3-conductor heavy-duty cord required.

⚠ CAUTION

Do not exceed amperage ratings of the extension cord. Undersized extension cords result in excessive drops in voltage, causing the electric motor to generate excessive heat. This condition results in inefficient motor operation and premature motor failure. **This will void the warranty.**

AMPERAGE REQUIREMENTS

MODEL	VOLTS ± 10%	FREQUENCY (Hz)	RUNNING AMPS
CS6-210	120	60	1.24
CS6-210-HV	120	60	2.04

Table 1: Electrical Requirements

3-CONDUCTOR HEAVY- DUTY EXTENSION CORD REQUIREMENTS

LENGTH (Ft)	CORD SIZE			
	16 GA	14 GA	12 GA	10 GA
0-50	13 A	18 A	25 A	30 A
50-100	10 A	13 A	18 A	25 A

Table 2: Cord Size Requirements

4.0 OPERATING PROCEDURES

There are 3 factors to consider when determining where to place the COOL-SPACE unit.

- 1. Fresh air supply:** The inlet of the unit (mesh sides) require a constant, uninterrupted supply of fresh air for maximum performance. A distance of 3 feet clear space to any obstructions at the rear or inlet side of the unit is recommended.
- 2. Discharge air flow:** The cool air discharged from the unit should be free of obstruction to allow the air to circulate in order to maximize the cooling zone.
- 3. Ventilation:** In order to operate at maximum effectiveness, it is helpful to have provisions to remove the air discharged from the unit from the cooling area. This ensures that the unit does not recirculate air that has already been through the evaporative cooling process.

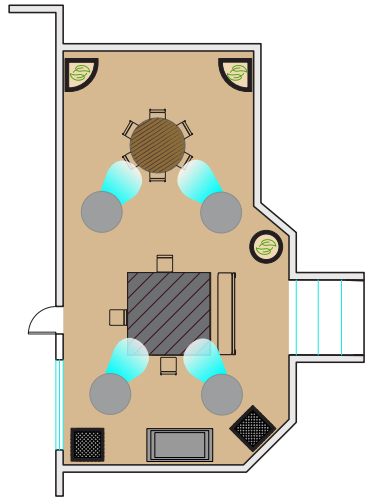

The unit must be placed on level ground to operate correctly. Units create an oval shaped air pattern. Obstacles such as racks and workbenches may interfere with the air flow. An attempt should be made to locate the unit in such a manner that interruption of the air pattern is held to a minimum. Multiple units may be required to cover larger areas.

4.1 FILLING THE UNIT WITH WATER

Once the COOL-SPACE unit has been connected to a water source as described in 3.1, turn the water supply valve on and the unit will fill with water. The float valve will shut off the water flow when the sump is full.

⚠ CAUTION

Prolonged use of hard water without proper water treatment will create mineral deposit build up causing pump to fail. Failures due to poor water quality are excluded from the warranty.

4.0 OPERATING PROCEDURES

4.2 STARTING THE PUMP

INITIAL START-UP

On initial start-up the cooling media in your new unit will take a few hours to become fully saturated. During this time an odor may emanate from them. This odor will dissipate over time. For best results change the water in the reservoir a few times.

SUBSEQUENT START-UPS

On subsequent start-ups turn on the pump, start the fan and cool down.

LOW WATER INDICATOR

The FLURRY is equipped with a low water indicator light.

- ◇ When the power is on and there is sufficient water in the reservoir, the light will be lit green, and the pump will be running.
- ◇ When the power is on and the water in the reservoir is getting low, the light will be lit red, and the pump will stop running.



4.3 STARTING THE FAN

Turn the fan control knob clockwise to turn on the fan and adjust the speed to your preferred setting.

5.0 MAINTENANCE AND STORAGE

WARNING

ELECTRICAL SHOCK HAZARD

Disconnect the power supply before performing any service or maintenance. Failure to do so may result in serious injury or death.

5.1 REMOVING THE COOLING MEDIA

In order to perform any maintenance on internal components, the cooling pads must be removed to access the inside of the unit.

1. Pop pad grilles from support channel.
2. Tilt pads from the top; lift out of the unit.

5.2 DAILY MAINTENANCE

Turn off the pump approximately 15 minutes before the fan is turned off at the end of each use. This allows the pads to drain and dry out - controlling mildew and bacteria growth and ensuring long and efficient pad life.

Drain water in the unit if it will be unused for a prolonged period of time.

5.3 PERIODIC MAINTENANCE

The cooling media (pads) acts as a filtering agent and removes dust and other particles from the incoming air stream. These particles will flow into the sump and collect there. Water impurities will also collect in the sump (water treatment tablets available at cool-space.com). In order to keep the FLURRY operating at peak efficiency you will need to keep the cooling media and the sump clear of debris.

DRAINING THE WATER SUMP

1. Turn unit off and disconnect the power supply
2. Remove drain plug located at bottom of reservoir; let unit drain
3. Remove cooling pads (refer to section 5.1)
4. Clean out reservoir with either a towel or wet/dry vacuum
5. Reinstall pads and grille

NOTE: Depending on how often you operate the unit, this procedure should be performed anywhere from every week for heavy use to monthly for light use.

5.3 PERIODIC MAINTENANCE *(CONTINUED)*

CLEANING THE COOLING MEDIA

To keep the COOL-SPACE unit operating at peak efficiency, ensure that the cooling pads are kept clean and dust-free. Dust and other particles have an adverse effect on the media's ability to introduce water into the air stream. If the pad surface becomes dirty or dusty, clean with a soft brush and water (never use bleach).

5.4 STORAGE

- ◆ Remove the pads, as described in section 5.1
- ◆ Clean with a soft brush and water to remove dust and debris.
- ◆ Drain sump using procedure described in section 5.3
- ◆ Wipe dry
- ◆ Store in a dry area and cover to prevent dust build-up

6.0 TROUBLESHOOTING/REPAIR

WARNING

ELECTRICAL SHOCK HAZARD

Disconnect the power supply before performing any service or maintenance. Failure to do so may result in serious injury or death.

CAUTION

Please use caution when troubleshooting or repairing all electrical components. Be certain that all power is disconnected from the unit before the pads or fan guard are removed to gain access to the fan.

NECESSARY TOOLS

Although the COOL-SPACE unit is designed to be simple to maintain, it will be necessary to have some basic hand tools - screwdrivers, pliers, adjustable wrenches, etc. - as well as a volt/ohm meter when troubleshooting the electrical system.

6.1 TROUBLESHOOTING

The FLURRY consists of three systems:

- Pump,
- Water Distribution System
- Fan System

It is important to determine which system(s) of the unit the problem is associated with.

When determining which system has a problem, you must define the associated problem, (e.g. the pump is not running). Several things may cause this particular problem so carefully check all systems to fully understand the extent of the problem.

If you have a complete understanding of all of the systems of the FLURRY, and how they depend on each other, it will be simple to define and solve any problem.

6.2 TROUBLESHOOTING GUIDES

PUMP

Pump motor will not run when switch is turned on

Turn fan on to check for power

- If fan doesn't start check breaker and cord plug-in
- If fan does start; check for power to and through pump switch (when turned on)

Ensure water level is high enough to make the low- water cut-off circuit

Fill water reservoir

Pump motor hums when switch is Turned on, but does not pump water

Obstruction in impellor

Remove object(s)

Pump motor failure

Replace pump

Breaker trips or fuse blows when switch is turned on

Check power cord length and breaker rating

Refer to page (2) for unit amperage draw and to determine required cord gauge

Check for locked-up pump

Replace pump

Pump runs but does not pump water

Air lock in outlet side of pump

Turn off and on to bleed

Ensure the impellor is turning in pump

If not, replace pump

6.0 TROUBLESHOOTING/REPAIR

6.2 TROUBLESHOOTING GUIDES (CONTINUED)

WATER DISTRIBUTION SYSTEM

The water distribution system consists of two (2) assemblies:

1. The Water Inlet Assembly
 - Brass bulkhead fitting
 - Float valve assembly
2. The Hose and Valve Assembly
 - Drip Channel
 - Valve Assembly
 - Connection Hose

Floor at side of unit is wet

Water inlet hose is loose at supply hose or inlet hose is loose at bulkhead fitting.

Tighten connections and/or replace hose washers.

Water overflows from reservoir

Float valve hose is loose at bulkhead fitting or at float valve.

Tighten connections and/or replace hose washers

Water pressure is too high to allow float valve to shut off (120psi max)

Reduce water pressure by adding an inline reducer

Float valve not properly seated

Check all hoses for leaks

Water spitting from the unit

Check The Hose and Valve Assembly

- Reduce flow control setting
- Replace cracked hose and valve assembly
- Tighten hose connections

Water leaking from drain plug

Check that plug is tightly seated in hole

- Tighten drain plug
- Replace drain plug

Too many dry streaks on the pads

Check for blocked holes in the drip channel or adjust water flow

- Remove and clean tube and holes
- Open water flow control valve

Unit will not fill

Check float screen

Clean

Float not functioning

Replace



6.2 TROUBLESHOOTING GUIDES (CONTINUED)

FAN SYSTEM

Fan won't run - makes no sound

Check power cord, extension cord, switches, circuit breaker

Reconnect power or extension cord; Reset breaker

Fan won't run - makes humming sound

Check Capacitor

Re-center blade hub

Motor stalled (will not turn by hand)

Replace motor

Breaker trips/fuse blows when fan starts

Motor stall

Replace motor

Check power source for min. 120 volt/10 amp

Upgrade power supply

Extension cord gauge too small

Replace with heavier cord

Motor overheats, shuts off and restarts several minutes later

Extension cord gauge too small

Replace with heavier cord

Inlet air obstructed or too close to wall

Provide minimum 3 feet inlet clearance

Faulty motor

Replace motor

Fan motor won't run - switch makes soft clicking sound

Ensure that switch is making good contact

Replace switch if needed

Fan blade doesn't turn - unit makes squealing sound

Motor stall (will not turn by hand)

Replace motor

Fan will not reach speed but turns and makes humming sound

Check Capacitor (where visible) and motor electrical connections

Replace capacitor or motor

Extension cord gauge too small

Replace with heavier cord

6.0 TROUBLESHOOTING/REPAIR

6.3 FAN REPAIR PROCEDURES

CAUTION

Repairs should be performed by a qualified technician!

WARNING

ELECTRICAL SHOCK HAZARD

Disconnect the power supply before performing any service or maintenance. Failure to do so may result in serious injury or death.

FAN MOTOR REPLACEMENT FOR CS6-210 & CS6-210-HV

1. Remove cooling pads (see section 5.1 for pad removal instructions)
2. Remove the black motor wiring plate and disconnect motor wires. (Mark each wire with a marker or marker tape to allow for easy matching when installing new motor.)
3. Remove louver
4. Remove the (4) nuts and bolts that mount the motor, fan, and support braces (complete fan assembly).
5. Replace new fan assembly.
6. Secure with (4) nuts and bolts.
7. Replace any wire ties that were removed when taking out the old fan assembly.
8. Replace the black motor wiring plate.
9. Reinstall pads and connect power

6.4 PUMP REPAIR PROCEDURES

CAUTION

Repairs should be performed by a qualified technician!

WARNING

ELECTRICAL SHOCK HAZARD

Disconnect the power supply before performing any service or maintenance. Failure to do so may result in serious injury or death.

PUMP REPLACEMENT FOR CS6-210 & CS6-210-HV

1. Remove cooling pads (see section 5.1 for pad removal instructions)
2. Remove switch plate and disconnect pump wire (refer to wiring diagram on page 14).
3. Remove hose and level switch from pump.
4. Remove pump from water sump and install new pump.
5. Reverse the above procedures to reconnect the wiring, level switch and reconnect the hose. Secure wires to fan frame with wire ties to clear the fan blades. Be sure to position the plug correctly.
6. Reinstall cooling pads and guards, reconnect power and test pump.

6.0 TROUBLESHOOTING/REPAIR

6.5 WIRING DIAGRAM

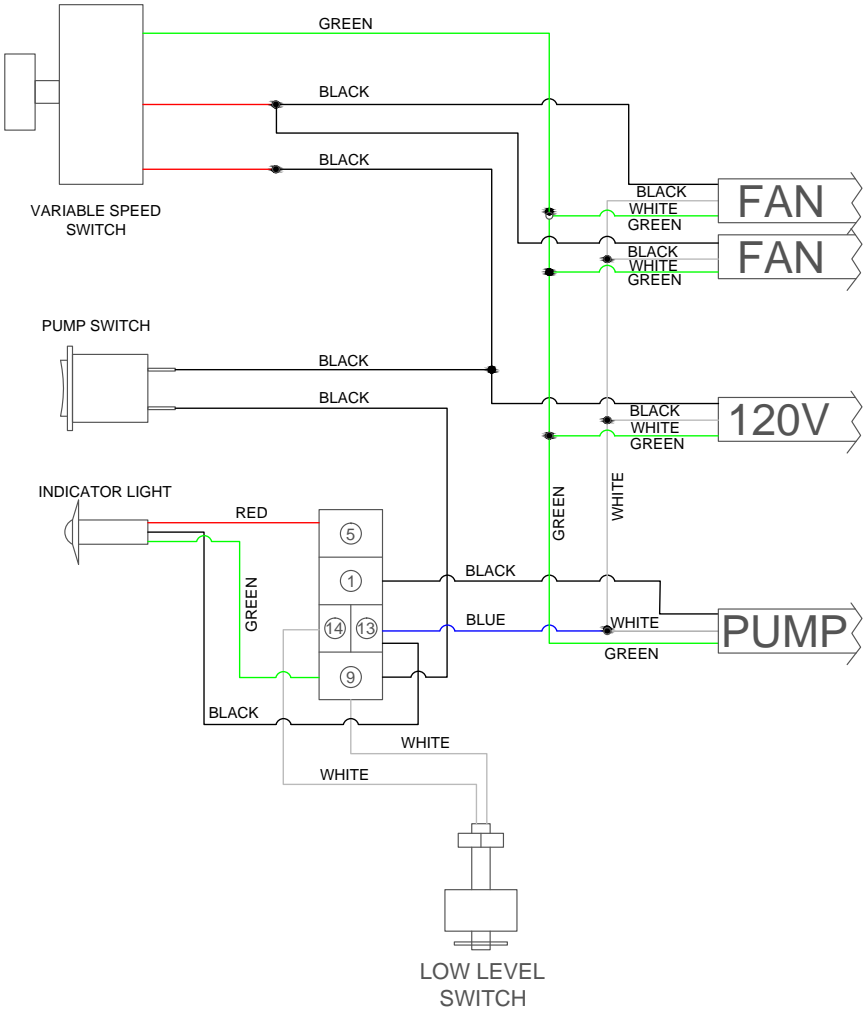

6.6 TECHNICAL SUPPORT

Technical support and service are available through the COOL-SPACE Technical Support Line at:

1-800-557-5716

support@cool-space.com

www.cool-space.com/support

The limited warranty is sixty (60) months from date of invoice. Refer to the manufacturer's Warranty Policy for details. (Applies to units purchased after January 1, 2019)

7.1 WARRANTY REGISTRATION

You must register your COOL-SPACE Portable Evaporative Cooler within fifteen (15) days of initial purchase to validate your cooler's warranty. You may register online at www.cool-space.com.

7.2 WARRANTY PARTS

Warranty replacement parts are available through COOL-SPACE. If you have any questions or concerns, please contact us direct at 1-800-557-5716 or at sales@cool-space.com. Please have your model number and serial number ready.

IMPORTANT
DO NOT DISCARD FAULTY PARTS
Check with the Manufacturer they may need to be returned for warranty credit.

7.3 OPTIONAL ACCESSORIES AND REPLACEMENT PARTS

Accessories and replacement parts are available from your local distributor or supplier or they can be found online at www.cool-space.com.



315 N Madison Street
Fortville, IN 46040
317-577-0417 · 800-557-5716
support@cool-space.com
COOL-SPACE.com

