

KÄRCHER

makes a difference

B 150 R
B 200 R



Deutsch	3
English	17
Français	30
Italiano	43
Nederlands	56
Español	70
Português	84
Dansk	98
Norsk	110
Svenska	122
Suomi	134
Ελληνικά	147
Türkçe	163
Русский	176
Magyar	192
Čeština	205
Slovenščina	218
Polski	231
Românește	245
Slovenčina	258
Hrvatski	271
Srpski	284
Български	297
Eesti	312
Latviešu	324
Lietuviškai	338
Українська	351
العربية	378





Register and win!
www.kärcher.com/register-and-win

ERC



59603660 (02/20)

  Please read and comply with these original instructions prior to the initial operation of your appliance and store them for later use or subsequent owners.

Contents

Safety instructions	EN	..	1
Function	EN	..	1
Proper use	EN	..	1
Environmental protection	EN	..	1
Control elements	EN	..	2
Overhead guard (option)	EN	..	3
Before Startup	EN	..	3
Operation	EN	..	5
Grey Intelligent Key	EN	..	7
Transport	EN	..	8
Storage	EN	..	8
Care and maintenance	EN	..	8
Troubleshooting	EN	..	10
Technical specifications	EN	..	12
Accessories and Spare Parts	EN	..	13
Warranty	EN	..	13
EU Declaration of Conformity	EN	..	13

Safety instructions

Before using the appliance for the first time, read and observe these operating instructions and the accompanying brochure: Safety information for brush cleaning units 5.956-251.0.

The appliance has been approved for use on surfaces with max. gradients as listed under "Technical Specifications".

Safety Devices

Safety devices serve to protect the user and must not be rendered in operational or their functions bypassed.

Safety Switch



To take all functions out of operation immediately: Bring the safety switch into the "0" position.

- When switching off the safety switch, the appliances brakes hard.
- The emergency-stop has a direct effect on all machine functions.

Seat switch





Switches off the drive motor after a short delay, if the operator leaves the operator seat during operation or while moving.

Symbols on the machine

	CAUTION Risk of injury on account of being crushed. Keep hands away from this area while swivelling down the waste water tank.
	DANGER Increased risk of accidents due to high speed. Drive slowly on slopes.

	DANGER Risk of electric shock during the charging process. Do not remove the terminal protective covers from the battery terminals and ensure correct installation.
--	---

Additionally for devices with an overhead guard

	DANGER The overhead guard pulls the waste water tank backwards when pivoting due to the increased weight.
	The unit can tip over and injure persons. Pivot the waste water tank slowly while holding it to check the speed.
	WARNING Danger of crushing Strong forces act upon the waste water tank when pivoting forwards. When pivoting forwards, make sure that there are no body parts between the waste water tank and the device.
	ATTENTION Danger of tipping over The overhead guard increases the danger of tipping. Drive slowly on slopes and inclines and steer carefully.

Danger or hazard levels

DANGER
Immediate danger that can cause severe injury or even death.

WARNING
Possible hazardous situation that could lead to severe injury or even death.

CAUTION
Pointer to a possibly dangerous situation, which can lead to minor injuries.

ATTENTION
Pointer to a possibly dangerous situation, which can lead to property damage.

Function

The scrubber vacuum is used for wet cleaning or polishing of level floors. You can adjust the machine to suit the cleaning task by modifying the settings for water quantity, contact pressure of the brushes, detergent quantity and driving speed.



Proper use

This appliance is suited for the commercial use, e.g. in hotels, schools, hospitals, factories, shops, offices, and rental companies.

Use this appliance only as directed in these operating instructions.

- The appliance may only be used for the cleaning of hard surfaces that are not sensitive to moisture and polishing operations.
- This appliance is intended for inside use.
- The application temperature ranges from +5°C to +40°C.
- The appliance is not suited for the cleaning of frozen grounds (e.g. in cold stores).
- The appliance is suitable for a max. water depth of 1 cm. Do not drive into an area where there is a risk of this max. water height being exceeded.
- The appliance may only be equipped with original accessories and spare parts.
- When using chargers or batteries, only the components approved in the operating instructions may be used. A different combination must be confirmed by the responsible charger and/or battery supplier.
- The appliance is not intended for the cleaning of public traffic routes.
- The machine should not be used on surfaces that are sensitive to pressure. Please consider the allowed load per surface unit of the floor. Details of load per surface unit can be found in the technical data.
- The appliance is not suited for the use in potentially explosive environments.
- The machine should not be used to suck in inflammable gases, undiluted acids or solvents.
This includes petrol, thinning agents or hot oil that can form an explosive mixture when it comes in contact with sucked air. Do not use acetone, undiluted acids and solvents as they are aggressive towards the materials from which the appliance is made.

Environmental protection

	The packaging materials are recyclable. Please do not throw packaging in the domestic waste but pass it on for recycling.
	Old units contain valuable recyclable materials. Batteries, oil and similar substances may not be released into the environment. Therefore please dispose of old units through suitable collection systems.

Notes about the ingredients (REACH)

You will find current information about the ingredients at:

www.kaercher.com/REACH

Control elements

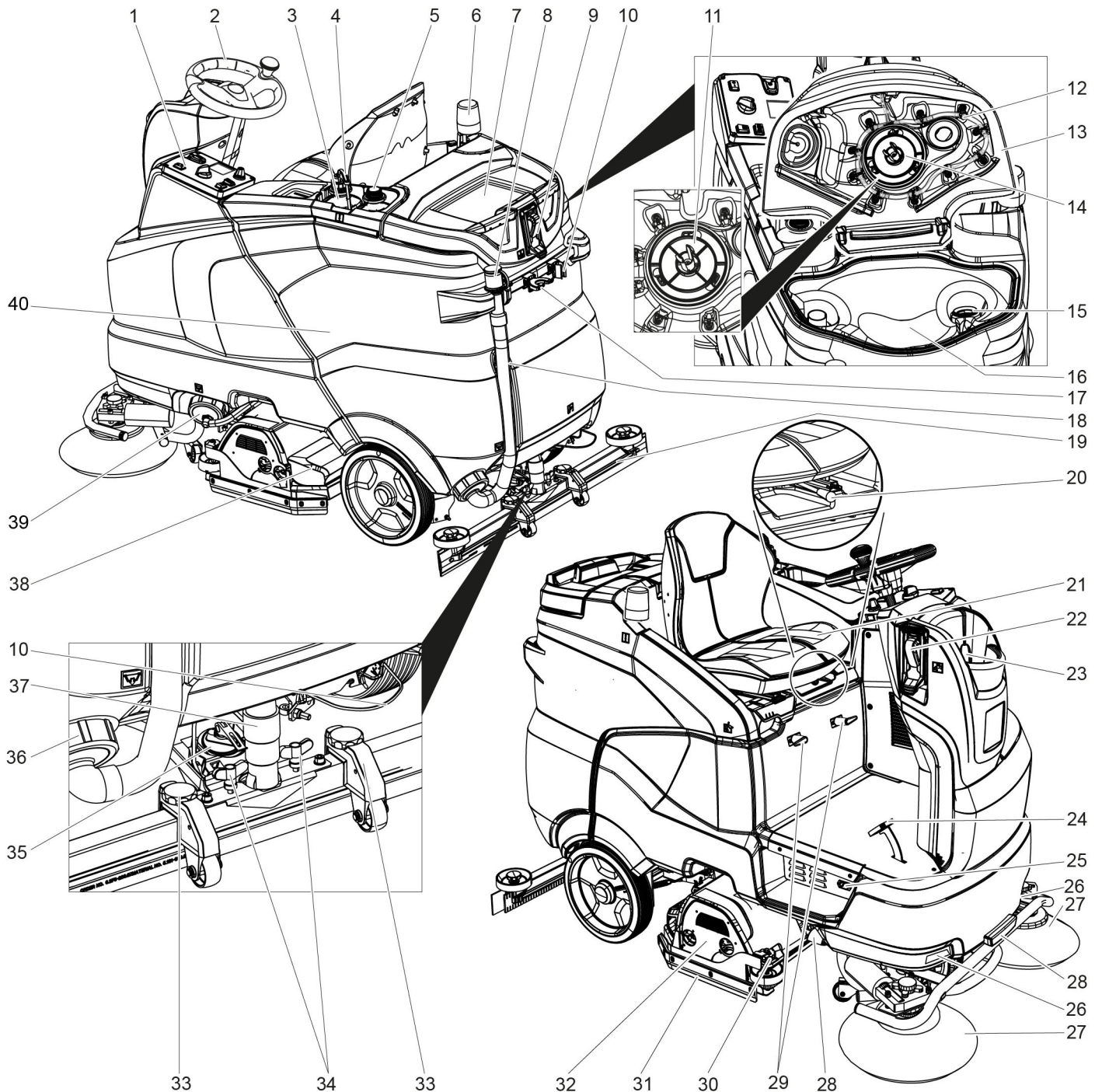

- | | | |
|---|---|---|
| 1 Operating field | 16 waste water tank | 34 Wing nuts for fastening the vacuum bar |
| 2 Steering wheel | 17 Tool holder ** | 35 Rotary handle to incline the vacuum bar |
| 3 Detergent bottle (only Dose model) | 18 Dirt water discharge hose | 36 Lock, waste water tank |
| 4 Suction hose for detergent (only Dose model) | 19 Vacuum bar * | 37 Suction hose |
| 5 Space for second detergent bottle | 20 Lever for seat adjustment | 38 Waste container (only with R cleaning head) * |
| 6 Warning lamp ** | 21 Seat (with seat switch) | 39 Closure fresh water tank with fresh water filter |
| 7 Storage surface for cleaning set "Home base box" | 22 Filling system ** | 40 Battery ** |
| 8 Drain hose for wastewater with dosing unit | 23 Fresh water tank cover | |
| 9 Water connection for waste water tank rinsing system ** | 24 Drive pedal | |
| 10 Mop holder ** | 25 IEC connector for charging cable (Only with variants with built-in charger). | |
| 11 Protective turbine strainer (under the float) | 26 Daytime running light | |
| 12 Waste water tank rinsing system ** | 27 Side brush (only SB version) | |
| 13 Cover waste water tank | 28 Work light ** | |
| 14 Float | 29 Cable hook | |
| 15 Fluff filter | 30 Adjustment wheel for wiping flap* | |
| | 31 Wiping flap | |
| | 32 Cleaning head * | |
| | 33 Height adjustment of suction bar | |

* not included in the delivery
** option

Operator console

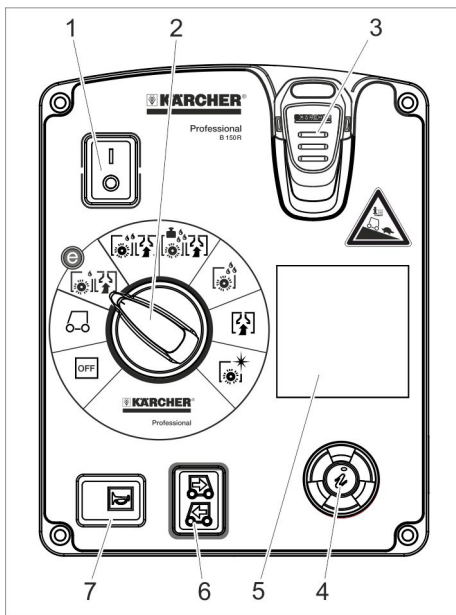

- 1 Safety button
- 2 Programme switch
- 3 Intelligent Key
- 4 Info button
- 5 Display
- 6 Drive direction switch
- 7 Horn

Programme switch

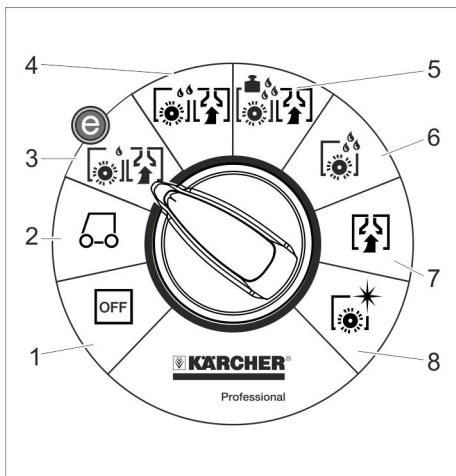

- 1 **OFF**
Device is switched off
- 2 **Transport run**
Driving to the Place of Use.
- 3 **Eco programme**
Wet clean the floor (with reduced brush speed) and vacuum up wastewater (with reduced suction).
- 4 **Scrubbing suction**
Wet clean the floor and vacuum up dirt water.
- 5 **Heavy programme**
Wet clean the floor (with increased brush contact pressure) and vacuum up dirt water.
- 6 **Scrubbing**
Wet clean the floor and allow the detergent to react.
- 7 **Vacuuming**
Suck in the dirt fleet.
- 8 **Polishing**
Polishing the floor without the application of liquid.

Symbols on the machine

	Handle for swivelling up the waste water tank
	Lashing point
	Mop holder **
	Water connection filling system **
	Water connection for waste water tank rinsing system **
	Drain outlet fresh water tank
	Drain outlet waste water tank

** option

Overhead guard (option)

The overhead guard protects the driver of the device from falling objects. On devices with an overhead guard, the waste water tank is equipped with a safety lock. This safety lock prevents the waste water tank from pivoting back unintentionally through forces acting on the overhead guard.

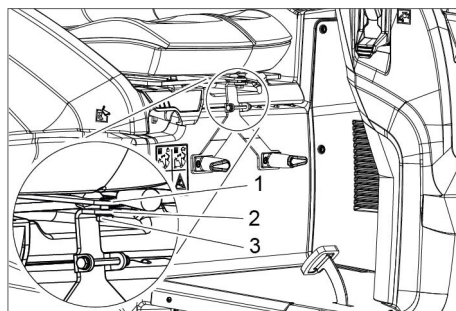

- 1 Overhead guard
- 2 Locking plate
- 3 Locking screw M8x16, washer

Pivoting the waste water tank backwards

- ➔ Empty the waste water tank.
- ➔ Unscrew the locking screw.
- ➔ Hold the waste water tank firmly and slowly pivot it backwards.

Pivoting the waste water tank forwards

⚠ WARNING
Danger of crushing
Strong forces act upon the waste water tank when pivoting forwards. When pivoting forwards, make sure that there are no body parts between the waste water tank and the device.

- ➔ Hold the waste water tank firmly and pivot it forwards.
- ➔ Screw in and tighten the locking screw.

Before Startup

Batteries

	Observe the directions on the battery, in the instructions for use and in the vehicle operating instructions
	Wear eye protection
	Keep children away from acid and batteries
	Danger of explosion
	Fire, sparks, naked flames and smoking must be strictly avoided
	Danger of chemical burns
	First aid
	Warning note
	Disposal
	Do not throw the battery into the regular waste

⚠ DANGER

Risk of explosion!
Do not place tools or similar items on the battery. Risk of short-circuit and explosion. Risk of injury. Ensure that wounds never come into contact with lead. Always clean your hands after having worked with batteries.

Recommended batteries

	Order No.	Volume [m ³]*	Air flow [m ³ /h]**
Battery set 240Ah, trough, low-maintenance	4.035-987.7	27	10.8
Battery set 180Ah, trough, low-maintenance	4.035-988.7	20.25	8.1
Battery set 240Ah, 6 blocks, maintenance-free	4.654-306.7	6.975	2.79

Battery set 180Ah, 6 blocks, maintenance- free	4.654- 307.7	5.175	2.07
---	-----------------	-------	------

* Minimum volume of the battery charging room

** Minimum air flow between the battery charging room and the surroundings

Insert batteries and connect

The "Pack" model contains built-in batteries.

- ➔ Bring the safety switch into the "0" position.
- ➔ For devices with a overhead guard, always observe the notes in the "overhead guard" chapter.
Tilt the waste water tank backwards.

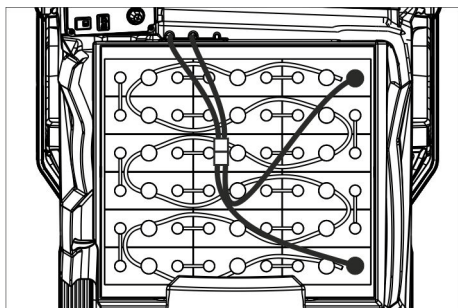

4.035-987.7

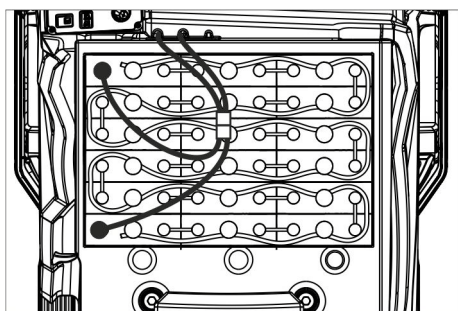

4.035-988.7

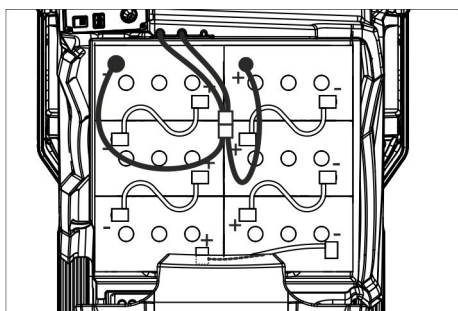

4.654-306.7 (arrangement A)

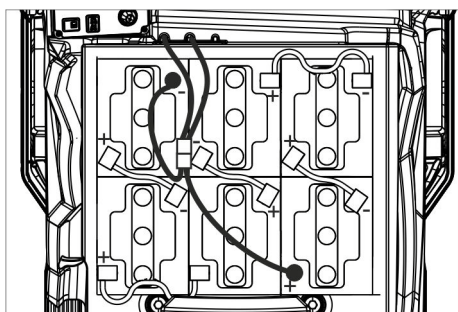

4.654-307.7 (arrangement B)

ATTENTION

Risk of damage. Ensure correct polarity.

- ➔ Connect pole using the enclosed connecting cable.

- ➔ Connect the connection cable to the free battery poles (+) and (-).
- ➔ Check for correct installation of the terminal protective covers.
- ➔ Insert battery plug.
- ➔ Set the battery type (see Chapter "Grey Intelligent Key").

ATTENTION

Risk of damage due to full discharge!

Charge the batteries before commissioning the appliance.

Charge the batteries

Note:

The appliance is equipped with a total discharge protection, i.e. if the still admissible minimum of the capacity is reached, the appliance can only be driven. The display shows the message "Battery low - cleaning not possible" and "Battery empty - please charge".

- ➔ Drive the appliance directly to the charging station; avoid any steep gradients in the process.

Note:

When using other batteries (e.g. batteries from other manufacturers), the total discharge protection level for the respective battery must be reset by the Kärcher after-sales service.

⚠ DANGER

Risk of electric shock. Observe supply network and fuse protection - see "Charger". Only use the charger in dry rooms with sufficient ventilation!

Note:

Average charging time is approx. 10 -12 hours.

The recommended chargers (suitable for the batteries used) are regulated electronically and will automatically terminate the charging process.

⚠ DANGER

Danger of explosion. The room, where the machine is kept to charge the battery, must feature a minimum volume and an air exchange with a minimum flow rate, depending on the type of battery (see "Recommended Batteries").

Danger of explosion. The charging of wet batteries is only permitted if the waste water reservoir is tilted up.

Variant with built-in charger

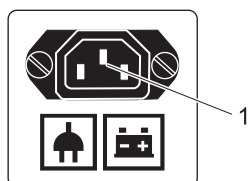

- 1 IEC connector for charging cable

- ➔ Connect the power cable with the IEC connector on the appliance.
- ➔ Connect the mains cable to the power supply system.

A battery symbol and the state of charge of the battery is shown on the display. The display lighting goes out.

Note:

During the charging process all cleaning and driving functions are blocked.

When the battery is fully charged, "Charging completed" is shown on the display.

- ➔ Pull the mains plug out of the socket and unplug the cable from the appliance after the charging process.
- ➔ Wind the mains cable around the cable holders.

Model without integrated charger

- ➔ Empty the waste water tank.
- ➔ Bring the safety switch into the "0" position.
- ➔ For devices with a overhead guard, always observe the notes in the "overhead guard" chapter.
Tilt the waste water tank backwards.
- ➔ Separate the battery plug and connect the charger cable.
- ➔ Plug in the mains plug of the charger.
- ➔ Execute the charging process according to the separate instruction manual of the battery charger.

Low maintenance batteries (wet batteries)

- ➔ Add distilled water one hour before the charging process comes to an end; follow the correct acid level. There are corresponding indicators on the battery. At the end of the charging process, all cells must gas.

⚠ DANGER

Danger of chemical burns. Filling water in while the battery is discharged can lead to acid leaks!

Wear goggles when handling battery acid and adhere to instructions to prevent injuries and damage to clothing.

Flush any acid drops on the skin or clothes immediately with plenty of water.

ATTENTION

Use only distilled or desalinated water (EN 50272-T3) for filling the battery.

Do not add any substances (so-called performance improving agents), else warranty claims will not be entertained.

Maximum battery dimensions

Layout	A	B
Length	244 mm	312 mm
Width	190 mm	182 mm
Height	275 mm	365mm

Information on the initial charge

Note:

With the initial charge, the control will not yet be able to detect which battery type has been installed. In this case, the battery indicator still works inaccurately.

A "V" to the right of the bar of the battery indicator shows that the initial charge has not been performed yet.

- ➔ Charge the battery until the display shows the maximum charge condition.
- ➔ Use the appliance until the deep discharge protection switches off the brush motor and the turbine after the initial charge of the batteries.

- Then correctly and completely charge the batteries.

After the initial charge, the "V" to the right of the battery indicator disappears.

Now the battery indicator works accurately.

Note:

If a battery type is selected in the battery menu, the procedure described above must be performed again. This is also the case if the already set battery type is reselected.

Battery display

The charge condition of the batteries is shown on the display of the control panel.

- The length of the bar indicates the charge condition of the battery.
- During the last 30 minutes the remaining operating time is indicated in minutes.

Removing the batteries

- Bring the safety switch into the "0" position.
- For devices with a overhead guard, always observe the notes in the "overhead guard" chapter. Tilt the waste water tank backwards.
- Clamp off the minus pole of the battery.
- Clamp off the remaining cables from the battery.
- Remove the batteries.
- Dispose of the used batteries according to the local provisions.

Unloading

Note:

To take all functions out of operation immediately, bring the safety switch into the "0" position.

- Four floor boards of the pallet are fastened with screws. Unscrew these boards.

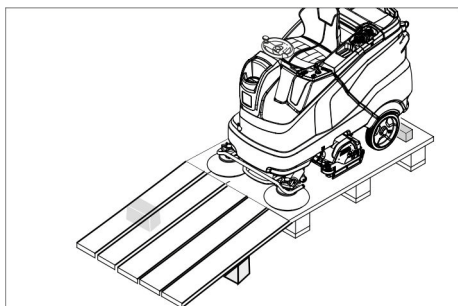

- Place the boards on the edge of the pallet. Place the boards in such a way that they lie in front of the four wheels of the machine. Fasten the boards with screws.
- Slide the four support beams included in the packaging under the ramp.
- Remove the wooden bars in front of the wheels.

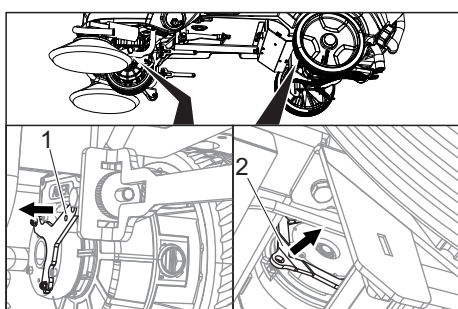

- 1 Front brake lever (all unit models)
- 2 Rear brake lever (only unit model Adv)

- Pull the brake lever and insert a coin between the lever and the brake.

Note:

The unit model Adv has a brake in the front and rear. To push the device, both brakes must be unlocked.

- Slowly push the machine down from the ramp.

⚠ DANGER

Danger of accident due to lacking braking effect.

- Remove the coin immediately after pushing the device.

or

- Plug in the Intelligent Key.
- Bring the safety switch into the "1" position.
- Set programme selector switch to transport run.
- Set the travel direction switch to "forward".
- Actuate the accelerator pedal.
- Drive the appliance off the pallet.
- Bring the safety switch into the "0" position.

Install cleaning head

The procedure for changing the cleaning head is described in the chapter "Maintenance Tasks".

Note:

On some models, the cleaning head is already installed.

Installing the Brushes

The installation of the brushes is described in the chapter "Maintenance Tasks".

Installing the Vacuum Bar

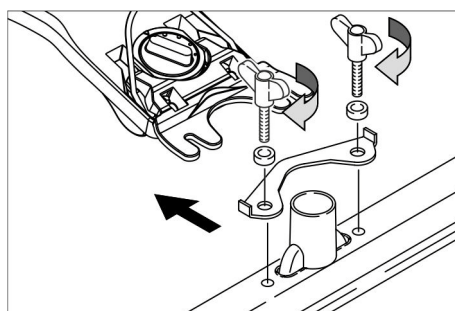

- Insert the vacuum bar into the vacuum bar suspension in such a manner that the profiled sheet is positioned above the suspension.
- Tighten the wing nuts.
- Insert the suction hose.

Operation

⚠ DANGER

Risk of injuries. Never use the unit without protective roof in areas where the operators can be hit by dropping objects.

Note:

To take all functions out of operation immediately, bring the safety switch into the "0" position.

Adjusting driver's seat

- Operate the lever for the seat adjustment and move the seat to the desired position.
- Release the seat adjustment lever and lock the seat in place.

Turning on the Appliance

- Take the seating position.
- Plug in the Intelligent Key.
- Bring the safety switch into the "1" position.
- Turn the programme switch to the desired function.
- If the relevant indication appears on the display, perform the maintenance task.

Display	Activity
Maintenance Vacuum bar	Clean the vacuum bar.
Maintenance Fresh water Filter	Clean the fresh water filter.
Maintenance Suction lip	Check vacuum lips for setting and wear and tear.
Maintenance Turbine strainer	Clean protective turbine strainer.
Maintenance Brush head	Check brush for wear and tear and clean it.

- Press Info button.
- Reset the counter for the corresponding maintenance (see "Care and maintenance/resetting counter").

Note:

If the counter is not reset, the maintenance indicator appears again with every start-up of the device.

Switching on the light

Daytime running light

The daytime running light is in operation when the device is switched on.

Work light (option)

- Set programme selector switch to transport run.
- Press Info button.
- Turn the info button until "Switch menu" is displayed.
- Press Info button.
- Turn the info button until "Work light" is highlighted.
- Press Info button.

Check parking brake

⚠ DANGER

Risk of accident. Prior to every operation, the parking brake must be checked for proper function on a level ground.

- Turn on the appliance.
- Set the travel direction switch to "forward".
- Set programme selector switch to transport run.
- Gently depress drive pedal.
- The brake must unlock audibly. The machine must roll easily on a plane surface. When the pedal is released, the brake locks audibly. Switch off the machine and call the aftersales service if the above-mentioned events do not occur.

Driving

⚠ DANGER

Danger of accident. If the machine does not brake, then proceed as follows:

- If the appliance does not stop when the accelerator is released on a ramp with more than 2% inclination, the safety switch may only be brought in the "0" position if the proper mechanical function of the parking brake has been checked prior to every operation of the appliance for safety reasons.
- Switch off the machine only after it comes to a complete halt (on an even surface) and call up the aftersales service!
- Further, follow all warning instructions for braking.

⚠ DANGER

Danger of tipping if gradient is too high.

- The gradient in the direction of travel should not exceed 10% (Adv 15%). Drive only lengthwise on uphill and downhill gradients, do not turn.

Danger of tipping when driving round bends at high speed.

Danger of slipping on wet floors.

- Drive slowly when cornering.

Danger of tipping on unstable ground.

- Only use the machine on sound surfaces. Danger of tipping with excessive sideways tilt.

NOTICE

Devices with an overhead guard must be driven more carefully due to the increased risk of tipping over.

Driving

⚠ DANGER

Danger of tipping over

Observe the maximum clearance height for devices with an overhead guard (see "Technical data"). If the overhead guard collides with obstacles, there is a risk of tipping over.

⚠ WARNING

On devices with an overhead guard, climb on board carefully so that your head does not hit the overhead guard.

- Take the seating position.
- Plug in the Intelligent Key.
- Bring the safety switch into the "1" position.
- Set programme selector switch to transport run.
- Set the drive direction using the drive direction button at the operator console.
- Determine the driving speed by pressing the drive pedal.
- Stop the machine: Release the drive pedal.

Note:

The direction of travel can also be changed while driving. This way even very dull spots can be polished by driving back and forth several times.

Overload

In case of overloading, the drive motor automatically switches off after a certain period. A fault message is displayed on the

console. The concerned unit gets switched off if the controls get overheated.

- Allow machine to cool down at least for 15 minutes.
- Turn the programme switch to "OFF", wait for a short period of time and turn it back to the desired programme.

Filling in detergents

Detergent

ATTENTION

Risk of damage. Only use the recommended detergents. With respect to different detergents the operator bears the increased risk regarding the operational safety and danger of accident.

Only use detergents that are free from solvents, hydrochloric acid and hydrofluoric acid.

Follow the safety instructions for using detergents.

Note:

Do not use highly foaming detergents.

Application	Detergent
Routine cleaning of all water resistant floors	RM 746 RM 780
Routine cleaning of glossy surfaces (e.g. granite)	RM 755 es
Routine cleaning and basic cleaning of industrial floors	RM 69 ASF
Routine cleaning and basic cleaning of fine stoneware tiles	RM 753
Routine cleaning of tiles in sanitary areas	RM 751
Cleaning and disinfection in sanitary areas	RM 732
Removal of coating from all alkali-resistant floors (e.g. PVC)	RM 752
Removal of coating from linoleum floors	RM 754

Fresh water

- Open the cover of the fresh water reservoir.
- Fill fresh water (max. 60 °C) until 15 mm below the upper edge of the tank.
- Pour in detergent.

Note:

If detergent is added to the detergent tank first before the water, this can result in a formation of a lot of foam.

- Close the cover of the fresh water reservoir.

Note:

Fill up the fresh water tank completely before starting up the machine to ventilate the water supply system.

Filling system (optional)

- Connect the water hose to the connection neck on the filling system.
- Open the water supply. Once the maximum fill level is reached, the built-in floater valve will stop the water inflow.
- Shut off water supply.
- Remove the water hose.

Metering system (only Dose model)

Detergent is added to the fresh water on the way to the cleaning head with the help of a dosaging device.

- Place the detergent bottle into the device.
- Close the bottle lid.
- Insert the suction hose of the dosaging equipment into the bottle.

Note:

The dosing unit can be used to add 3% detergent at maximum. With higher dosage the detergent must be put into the fresh water tank.

ATTENTION

Risk of clogging due to dried detergent when the detergent is added to the fresh water tank of the Dose version. The flow meter of the dosing equipment can agglutinate on account of drying detergent and hamper the functioning of the dosing equipment. Subsequently rinse the fresh water tank and the appliance with clear water. For rinsing, select cleaning programme with application of water at the programme selector switch. Set the water quantity to the highest value, set the detergent dosage to 0%

Note:

The appliance is equipped with a fresh water indicator in the display. If the fresh water tank is empty, the function of adding detergent gets deactivated. The cleaning head continues to work without liquid supply.

Setting the parameters

With yellow Intelligent Key

Parameters for the different cleaning programmes are preset in the appliance. Depending on the authorisation of the yellow Intelligent Key, individual parameters can be changed.

The modification of the parameters is only valid until another cleaning programme is selected via the programme selection switch.

If you wish to permanently change the parameters, you must use a grey Intelligent Key. This adjustment procedure is described in the section "Grey Intelligent Key".

Note:

Almost all displayed text regarding parameter adjustment is self-explanatory. The only exception is the parameter FACT:

- Fine Clean: Lower brush speed for removing the grey film on fine stone floors.
 - Whisper Clean: Medium brush speed for regular cleaning with reduced noise level.
 - Power Clean: High brush speed for polishing, crystallising and sweeping.
- Turn the program selection switch to the desired cleaning program.
 - Turn the info button until the desired parameter is displayed.
 - Press Info button - the set value blinks.
 - Set the desired value by turning the info button.
 - Confirm the changed setting by pressing the Info button or wait till the set value is automatically accepted after 10 seconds.

Setting the Vacuum Bar

Oblique position

To improve the vacuuming result on tiled floors the vacuum bar can be turned to an oblique position of up to 5°.

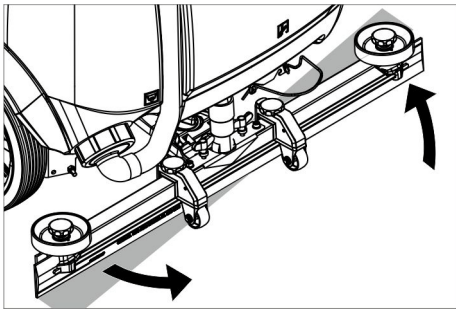

- Release the wing nuts.
- Turn the vacuum bar.
- Tighten the wing nuts.

Inclination

If the vacuum result is unsatisfactory the inclination of the straight vacuum bar can be modified.

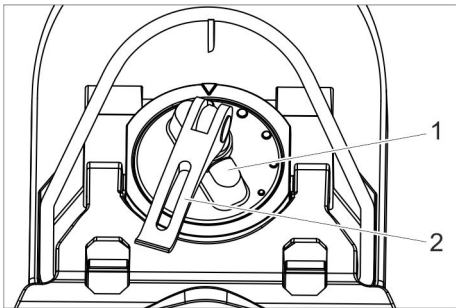

- 1 Turning handle
- 2 Tension lever

- Lift the tension lever.
- Adjust the rotary handle to incline the suction bar.
- Press the tension lever downwards.

Adjust wiping flaps

- Adjust the wiper flaps by turning the adjustment wheel so that they touch the floor.
- Turn the adjustment wheel an additional turn toward the bottom.

Spray nozzle (option)

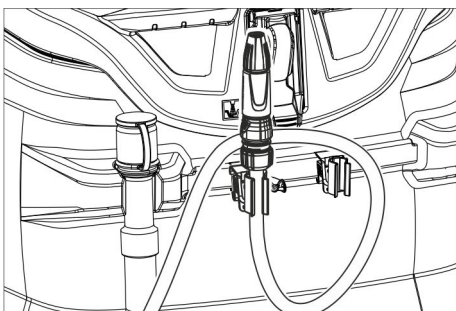

The hose with the spray nozzle is attached to the back of the appliance. It serves for washing away dirt and for manual cleaning of the wastewater tank.

- Turn programme selector switch to "transport run".
- Press Info button.
- Turn the info button until "tank rinsing" is shown on the display.

- Press Info button.
- Turn the info button until "ON" is displayed.
- Press Info button.
The water pump delivers fresh water through the spray nozzle.

Emptying the waste Water tank

Note:

Overflow waste water tank. When the wastewater tank is full, the suction turbine switches off and "Waste water tank full" is shown on the display.

⚠ WARNING

Please observe the local provisions regarding the wastewater treatment.

- Take the dirt water discharge hose from the support and lower above a suited collection device.

Note:

The wastewater flow can be controlled by squeezing the dosing unit.

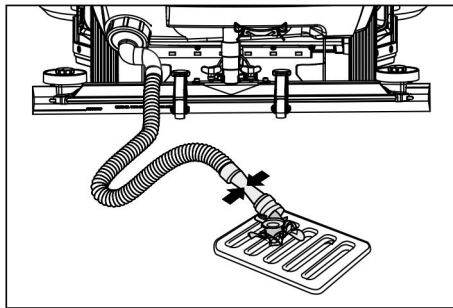

- Let off water by opening the dosage device at the discharge hose.
- Rinse the dirt water reservoir with clear water.

Emptying the Fresh Water Tank

- Open the lock of the fresh water reservoir.
- Drain the fresh water.
- Attach the closure of the fresh water tank.

Empty waste container (only with R cleaning head)

- Check the waste container. If needed, remove and empty waste container after work.

Shutting down

- Remove the Intelligent Key.
- Secure the machine with wheel chocks to prevent it from rolling away.
- Charge battery, if required.

Grey Intelligent Key

- Plug in the Intelligent Key.
- Select the desired function by turning the Info button.

The different functions are described in the following.

Transport run

- Turn programme selector switch to "transport run".
- Press Info button.
In the transport run menu the following settings can be made:

Key management

In this menu item the authorisations for yellow intelligent keys as well as the language of the display texts are selected.

- Turn the info button until "key managem." is shown on the display.
- Press Info button.
- Remove the grey Intelligent Key and insert the yellow Intelligent Key to be programmed.
- Select the desired menu item to be modified by turning the Info button.
- Press Info button.
- Adjust the menu item by turning the Info button.
- Confirm the setting by pressing the menu item.
- Select the next menu item to be modified by turning the Info button.
- In order to save the authorisations, call the "Save?" menu by turning the info button and then press the info button.
- "Continue key menu":
Yes: Programme further Intelligent Key.
No: Exit key menu.
- Press Info button.

Selecting the brush shape

This function is required when changing the cleaning head.

- Turn the info button until "brush head" is shown on the display.
- Press Info button.
- Turn the info button until the desired brush shape is highlighted.
- Press Info button.
- Move the hoist drive for replacement of the cleaning head by turning the info button:
up: Raise
down: Lower
OFF: Stop
- Exit menu: Select "OFF" by turning the info button and press the info button.

When exiting the menu, the control performs a restart.

Stopping times

- Turn the info button until "stopping times" is shown on the display.
- Press Info button.
- Turn the info button until the desired assembly is highlighted.
- Press Info button.
- Turn the info button until the desired stopping time is reached.
- Press Info button.

Setting the battery type

- Turn the info button until "Battery menu" is displayed.
- Press Info button.
- Turn the info button until the desired battery type is highlighted.
- Press Info button.

Standard setting

Changes of the parameters of the individual cleaning programmes that were made during the operation are reset to the basic setting after switching off the appliance.

- Turn the info button until "Basic setting" is displayed.

- Press Info button.
- Turn the info button until the desired cleaning programme is displayed.
- Press Info button.
- Turn the info button until the desired parameter is displayed.
- Press Info button - the set value blinks.
- Set the desired value by turning the info button.
- Press Info button.

Setting the language

- Turn the info button until "Language" is displayed.
- Press Info button.
- Turn the info button until the desired language is highlighted.
- Press Info button.

Switch menu

The work light can be enabled or disabled in this menu item.

- Turn the info button until "Work light" is highlighted.
- Press Info button.

Factory setting

The factory settings of all parameters are restored.

Cleaning Programs

Parameters that are adjusted with the grey Intelligent Key, are kept until another setting is selected.

- Turn the program selection switch to the desired cleaning program.
- Press the info button - the first adjustable parameter is displayed.
- Press Info button - the set value blinks.
- Set the desired value by turning the info button.
- Confirm the changed setting by pressing the Info button or wait till the set value is automatically accepted after 10 seconds.
- Select the next parameter by turning the Info button.
- After all desired parameters have been modified, turn the info button until "Exit menu" is displayed.
- Press the info button - you will exit the menu.

Transport

⚠ DANGER

Risk of injury! When loading or unloading the appliance, it may only be operated on gradients of max. 10% (Adv 15%). Drive slowly.

⚠ CAUTION

Risk of injury and damage! Observe the weight of the appliance when you transport it.

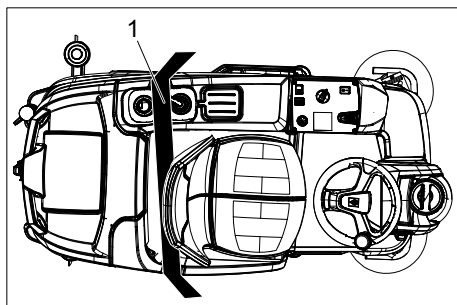

1 Lashing strap

- When transporting in vehicles, secure the appliance according to the guidelines from slipping and tipping over.

With mounted D cleaning head

- Remove brushes from the brush head.

Storage

⚠ CAUTION

Risk of injury and damage! Note the weight of the appliance in case of storage.

- This appliance must only be stored in interior rooms.
- Select the storage site for the appliance taking into consideration the permissible total weight of the appliance in order not to impact its stability.

Care and maintenance

⚠ DANGER

Risk of injury! Before working on the appliance, remove the Intelligent Key and the mains plug of the charger.

Pull out the battery plug.

- Drain and dispose of the dirt water and the residual fresh water.

⚠ CAUTION

Risk of injury due to overrun of the suction turbine.

Suction turbine will continue to run for a while after switch-off. Carry out maintenance tasks only after the suction turbine has come to a halt.

Maintenance schedule

After the work

ATTENTION

Risk of damage. Do not sluice the appliance with water and do not use aggressive detergents.

- Drain off dirt water.
- Clean protective turbine strainer.
- Only with R cleaning head Remove bulk waste container and empty it.
- Clean the outside of the appliance with a damp cloth which has been soaked in mild detergent.
- Clean the vacuum lips and the wiping lips, check for wear and replace if required.
- Check the brushes for wear, replace if required.
- Charge the battery:
If the charging state of the battery is under 50%, charge the battery fully and without interruption.
If the charging state of the battery is over 50%, only recharge the battery if the entire operation duration will be required when next used.

Weekly

- When used regularly, charge the battery fully and without interruption at least once a week.

Monthly

- During long operating pauses: Carry out refill charging for the battery.
- Check battery poles for oxidation, brush off if necessary. Ensure firm seating of the connection cable.

- Clean the seals between waste water tank and cover and check for tightness, replace if required.
- Check the acid density of the cells if the batteries are not maintenance-free batteries.
- Clean the brush tunnel (only R cleaning head)

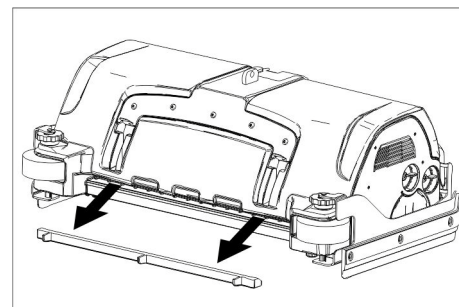

- Remove the water distribution strip from the cleaning head and clean water canal (only R cleaning head).
- For long periods of disuse, only turn the device off when the battery is fully charged. Fully recharge the battery at least every month.

Yearly

- Have the prescribed inspection carried out by the customer service.

Reset the counter

When a maintenance task indicated in the display has been performed, the relevant maintenance counter must be reset afterwards.

- Plug in the Intelligent Key.
- Bring the safety switch into the "1" position.
- Set programme selector switch to transport run.
- Press Info button.
- Turn the info button until "Maintenance counter" is displayed.
- Press Info button.
The counter readings are displayed.
- Press Info button.
"Delete counter" is indicated.
- Turn the info button until the counter to be deleted is highlighted.
- Press Info button.
- Select "YES" by turning the info button.
- Press Info button.
The counter is deleted.

Note:

The service counter can only be reset by the customer service.

The service counter indicates the time until the next service by the customer service is due.

Maintenance Works

Maintenance contract

To ensure a reliable operation of the appliance maintenance contracts can be concluded with the competent Kärcher sales office.

Cleaning the protective turbine strainer

→ Open the cover of the waste water tank.

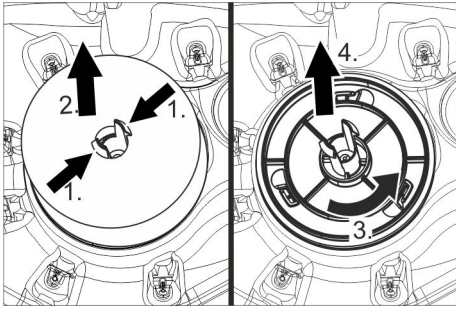

- Squeeze the locking hooks.
- Pull off the float.
- Turn the protective turbine strainer in a counter-clockwise direction.
- Remove protective turbine strainer.
- Rinse dirt off the protective turbine strainer with water.
- Reattach protective turbine strainer.
- Attach float.

Replacing the vacuum lips

- Remove the vacuum bar.
- Unscrew the star grips.

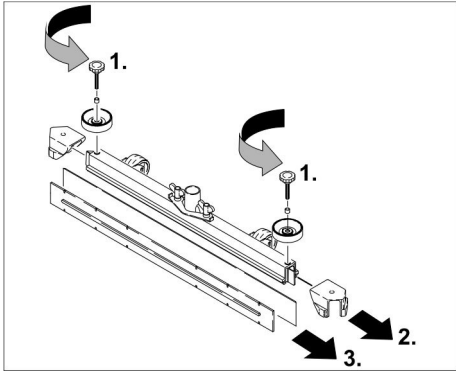

- Remove the plastic parts.
- Remove the vacuum lips.
- Insert new vacuum lips.
- Insert the plastic parts.
- Screw in and tighten the star grips.

Install D cleaning head

- Lift the holder of the cleaning head (see Chapter "Grey intelligent key/.../cleaning head replacement").
- Slide the cleaning head under the appliance so that the hose points toward the rear. Only slide the cleaning head halfway under the appliance.

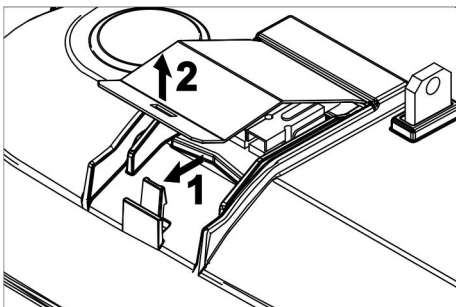

- Remove the lid of the cleaning head.

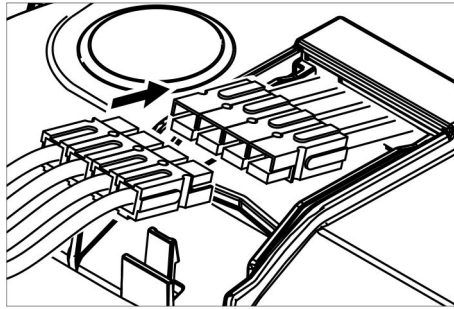

- Connect the power cord of the cleaning head to the appliance (same colours must meet).
- Replace the lid and lock it.
- Slide the cleaning head halfway under the appliance.

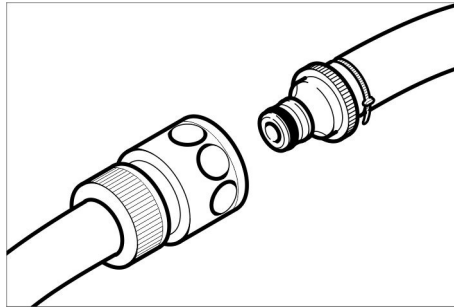

- Connect the hose couplers on the cleaning head to the hose on the appliance.

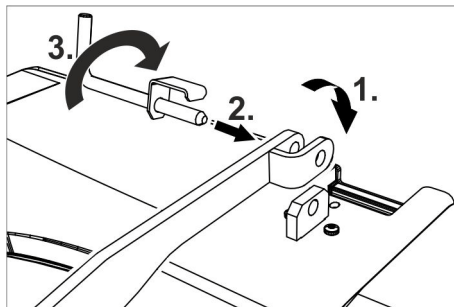

- Insert the tab into the middle of the cleaning head, between the fork of the lever.
- Align the holder of the cleaning head so that the drilled holes in the lever and the cleaning head match.
- Insert the stop pin through the bushings and swivel the locking plate downward.

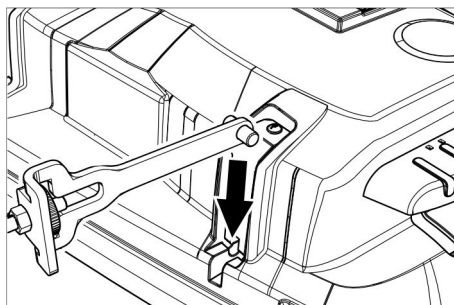

- Insert the cylinder pin into the boring of the drawbar.
- Slide the drawbar in the guide channel on the cleaning head all the way to the bottom.
- Insert the locking plate into the guide channel and lock it in.
- Repeat process on the drawbar on the opposite side.

- Insert the grey intelligent key.
- Set brush type "Disc".

Install R cleaning head

- Lift the holder of the cleaning head (see Chapter "Grey intelligent key/.../cleaning head replacement").
- Slide the cleaning head under the appliance so that the hose points toward the rear. Only slide the cleaning head halfway under the appliance.

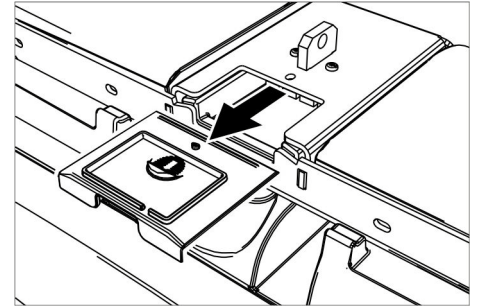

- Pull out the cover.

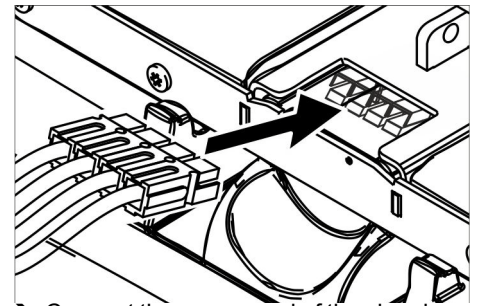

- Connect the power cord of the cleaning head to the appliance (same colours must meet).
- Push in the cover.
- Slide the cleaning head halfway under the appliance.

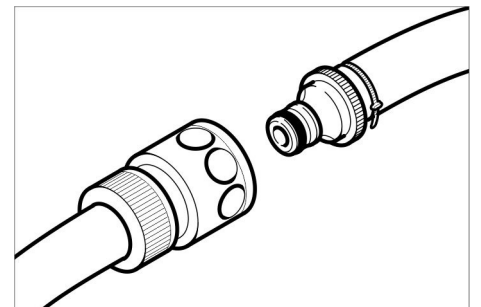

- Connect the hose couplers on the cleaning head to the hose on the appliance.

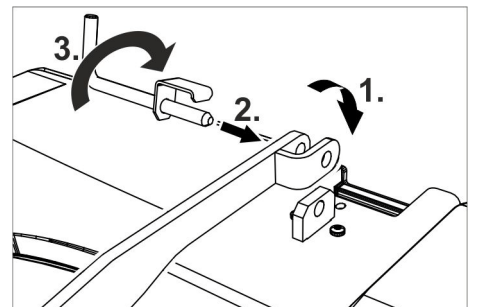

- Insert the tab into the middle of the cleaning head, between the fork of the lever.

- Align the holder of the cleaning head so that the drilled holes in the lever and the cleaning head match.
- Insert the stop pin through the bushings and swivel the locking plate downward.

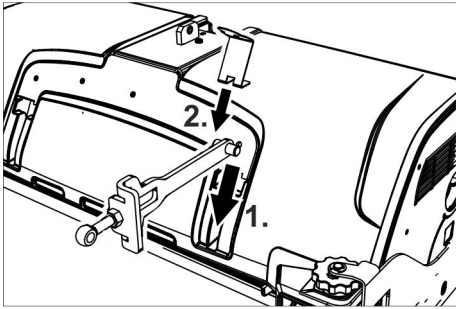

- Insert the cylinder pin into the boring of the drawbar.
- Slide the drawbar with the pin into the guide channel on the cleaning head all the way to the bottom and lock.
- Insert the locking plate into the guide channel and lock it in.
- Repeat process on the drawbar on the opposite side.
- Insert the grey intelligent key.
- Set brush type "Brush".

Remove D cleaning head

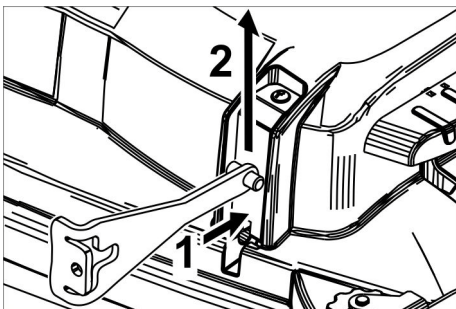

- Press in the locking plate and swivel the drawbar upward.
- The subsequent removal will take place in the opposite order of the installation.

Replacing the brush rollers

- Lift the cleaning head.

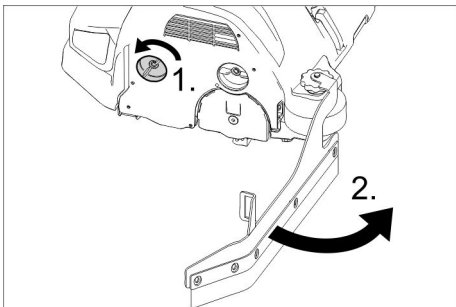

- Loosen the lock of the wiper flap.
- Swivel the wiping flap out of the way.

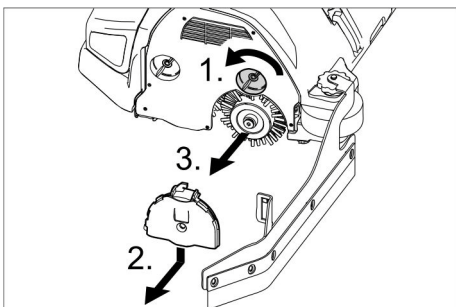

- Loosen the lock of the wiper flap.

- Push the bearing lid down and remove.
- Pull out the brush roller.
- Insert a new brush roller.
- Reattach the bearing lid and the wiper flap in reverse sequence.
- Repeat process on the opposite side.

Replacing the Disk Brushes

- Lift the cleaning head.

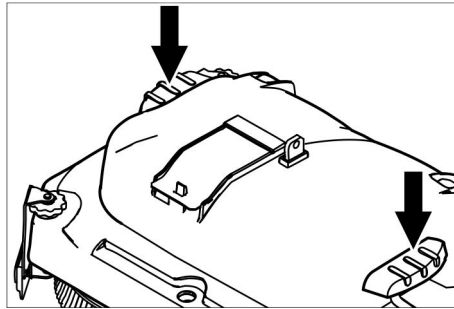

- Press the pedal for changing the brushes downward beyond its resistance.
- Pull the disc brush out of the side below the cleaning head.
- Hold the new disc brush under the cleaning head, push upward and lock.

Replacing the side brush (only with SB version)

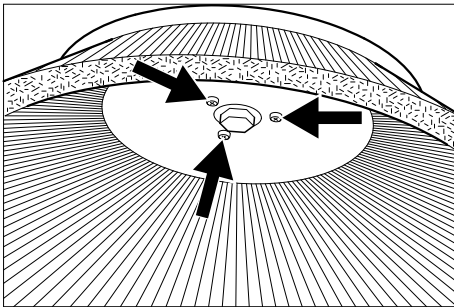

- Loosen 3 screws.
- Remove the wiper blade.
- Push in the new side brush.
- Tighten 3 screws.

Frost protection

In case of danger of frost:

- Empty the fresh and dirt water reservoirs.
- Store the appliance in a frost-protected room.

Troubleshooting

⚠ DANGER

Risk of injury! Before working on the appliance, remove the Intelligent Key and the mains plug of the charger.

Pull out the battery plug.

- Drain and dispose of the dirt water and the residual fresh water.

⚠ CAUTION

Risk of injury due to overrun of the suction turbine.

Suction turbine will continue to run for a while after switch-off. Carry out maintenance tasks only after the suction turbine has come to a halt.

In case of faults that cannot be remedied using the table below please contact the customer service.

Fault indication

If errors appear on the display, then proceed as follows:

Fault indication as text

- Execute instructions on the display.
- Acknowledge the fault by pressing the info button.

Fault indication as numerical code

- Turn the program selection switch to "OFF".
 - Wait till the text on the display has disappeared.
 - Turn the programme switch into the previous position.
- Only carry out the troubleshooting measures in the indicated order if the error occurs again. The key switch must be in the "0" position and the emergency stop button pressed.
- If the fault cannot be repaired, call customer service and mention the error message.

Note:

Fault messages that are not listed in the following table indicate faults that cannot be rectified by the operator. Please contact the aftersales service.

Faults with display

Display	Cause	Remedy
Seat switch open!	Seat contact switch has not been activated.	→ Release the drive pedal. Have a seat.
Release accelerator!	The gas pedal is depressed when the main switch is on.	→ Release drive pedal and reactivate.
No direction of travel!	Travel direction switch or cable connection defective.	→ Call customer service.
Battery discharged!	Battery voltage too low.	→ Charge battery.
Battery voltage inadmissible!	Battery voltage is above or below the admissible range.	→ Call customer service.
Charger defective!	Error on the charger, charging is not possible.	→ Check the charger.
Fresh water tank empty!	The fresh water tank is empty.	→ Fill up fresh water reservoir.
Brush pressure not reached!	Timeout brush contact pressure control.	→ Check brush wear, replace brush if required. → Check the function of the brush heads: lowering, raising.
Waste water tank full!	waste water tank is full.	→ Empty the waste water tank.
	Level sensor or cable connection defective.	→ Call customer service.
Brake defective!	Brake defective.	→ Do not drive the appliance. → Call customer service.
Propulsion motor hot! Allow to cool down!	Motor protection was triggered	→ Bring the safety switch into the "0" position. → Allow machine to cool down at least for 15 minutes. → Contact aftersales service in case of recurrence.
Horn defective!	Horn defective.	→ Call customer service.
Control is hot! Allow to cool down!	Performance electronics of lift module (A4) too hot	→ Bring the safety switch into the "0" position. → Allow control to cool down at least 5 minutes. → Significantly reduce the brush pressure with rough ground. → Contact aftersales service in case of recurrence.
Brush motors overloaded!	Load of the brush heads asymmetric.	→ Adjust brush level.

Faults without display on the console

Fault	Remedy
Appliance cannot be started	Seat switch not operated, sit down on the seat. The machine operates only if the operator is seated on the seat.
	Bring the safety switch into the "1" position.
	Set the programme switch to "OFF". Wait for 10 seconds. Set the programme selector switch to previous function. If possible, drive the appliance on level grounds only. Check parking brake and foot brake if necessary.
	Take the foot off the accelerator pedal prior to switching on the safety switch. If the fault recurs, call the aftersales service.
	Check battery; charge it, if needed
Insufficient water quantity	Check fresh water level, refill tank if necessary.
	Check hoses for blockages; clean if required.
	R cleaning head: Remove the water distributor strip and clean it.
	Clean the fresh water filter.
Insufficient vacuum performance	Clean the seals between waste water tank and cover and check for tightness, replace if required.
	Check protective turbine strainer for soiling, clean if necessary.
	Clean the vacuum lips on the vacuum bar, turn or replace if required
	Check if the cover on the dirt water discharge hose is closed
	Check suction hose for blockages; clean if required.
	Check the suction hose for tightness; replace if required.
	Check the setting of the vacuum bar.
Attach additional weight (accessory) to the vacuum bar.	
Insufficient cleaning result	Set/ adjust contact pressure.
	Adjust wiper lips.
	Check the brushes for wear, replace if required.
Brushes do not turn	Reduce contact pressure.
	Check if foreign matters block the brushes; remove foreign matter if required.
	Motor overloaded, allow to cool down. Set the programme switch to "OFF". Wait for 10 seconds. Set the programme selector switch to previous function.
Drain hose for dirty water is blocked	Open dosing equipment at the drain hose. Pull out the suction hose from suction beam and close it by hand. Set the program selection switch to suction or vacuuming. The blockage will be sucked out from the drain hose into the dirt water tank.
Detergent metering Dose (only Dose) does not function properly	Inform Customer Service.

Technical specifications

B 150 / B 200		R 75	D 75	R 90	D90	D110
Power						
Nominal voltage	V	36				
Battery capacity	Ah (5h)	180/240				
Average power consumption	W	2300	2200	2600	2400	2500
Mean power consumption Adv	W	3200	3100	3500	3300	-
Nominal power engine (Adv)	W	600 (1400)				
Suction engine output	W	750				
Brush engine output	W	2 x 600		2 x 750	2 x 600	2 x 600
Vacuuming						
Cleaning power, air quantity	l/s	27.3				
Cleaning power, negative pressure	kPa	21.1				
Cleaning brushes						
Working width	mm	750		900		1100
Brush diameter	mm	105	410	105	450	550
Brush speed	1/min	1200	180	1200	180	180
Dimensions and weights						
Driving speed, max. (Adv)	km/h	6 (10)				
Slope max. (Adv)	%	10 (15)				
Theoretical surface capacity (Adv)	m ² /h	4500 (7500)		5400 (10000)		6600
Volume of fresh water/waste water tank, B 150 / B 200	l	150 / 200				
Capacity coarse dirt container	l	7	-	9	-	-
Water pressure filling system**, waste water tank rinsing system**, max.	MPa (bar)	1 (10)				
Length, B 150 / B 200	mm	1690 / 1940				
Width (without suction bar), B 150 / B 200	mm	810 / 850	810 / 850	910 / 910	980 / 980	1110
Height	mm	1390				
Height with overhead guard (option)	mm	2060				
Permissible overall weight (Adv), B 150 / B 200	kg	820 (838) / 935 (--)				
Transport weight (Adv), B 150 / B 200	kg	586 (604) / 640 (--)				
Surface load (with driver and full fresh water tank)						
Front wheel, B 150 / B 200	N/cm ²	94 / 98				
Rear wheel, B 150 / B 200	N/cm ²	51 / 67				
Values determined as per EN 60335-2-72						
Vibration total value on arms	m/s ²	<2.5				
Vibration total value on seat area	m/s ²	<2.5				
Uncertainty K	m/s ²	0.1				
Sound pressure level L _{pA}	dB(A)	67				
Uncertainty K _{pA}	dB(A)	2				
Sound power level L _{WA} + Uncertainty K _{WA}	dB(A)	85				
Built-in charger (option)						
Nominal voltage	V	230				
Frequency	Hz	50/60				
Rated current	A	8				

** option

Accessories and Spare Parts

Only use original accessories and spare parts, they ensure the safe and trouble-free operation of the device.

For information about accessories and spare parts, please visit www.kaercher.com.

Warranty

The warranty terms published by the relevant sales company are applicable in each country. We will repair potential failures of your appliance within the warranty period free of charge, provided that such failure is caused by faulty material or defects in manufacturing. In the event of a warranty claim please contact your dealer or the nearest authorized Customer Service centre. Please submit the proof of purchase.

EU Declaration of Conformity

We hereby declare that the machine described below complies with the relevant basic safety and health requirements of the EU Directives, both in its basic design and construction as well as in the version put into circulation by us. This declaration shall cease to be valid if the machine is modified without our prior approval.

Product: Floor cleaner ride-on model
Type: 1.246-xxx, 2.246-xxx

Relevant EU Directives

2006/42/EC (+2009/127/EC)
2014/30/EU
1999/5/EC

Applied harmonized standards

EN 60335-1
EN 60335-2-29
EN 60335-2-72
EN 55012: 2007 + A1: 2009
EN 61000-6-2: 2005
EN 55014-1: 2017
EN 55014-2: 1997 + A2: 2008
EN 61000-3-2: 2014
EN 61000-3-3: 2013
ETSI EN 300 328 V1.9.1
ETSI EN 300 440-2 V1.4.1
ETSI EN 301 489-1 V1.9.2
ETSI EN 301 489-3 V1.4.1
ETSI EN 301 489-7 V1.3.1
ETSI EN 301 489-17 V2.2.1
ETSI EN 301 511 V9.0.2
ETSI EN 302 291-2 V1.1.1
EN 60950-1

Applied national standards

-

The signatories act on behalf of and with the authority of the company management.



H. Jenner

Chairman of the Board of Management



S. Reiser

Director Regulatory Affairs & Certification

Documentation supervisor:

S. Reiser

Alfred Kärcher SE & Co. KG
Alfred-Kärcher-Straße 28-40
71364 Winnenden (Germany)
Tel.: +49 7195 14-0
Fax: +49 7195 14-2212

Winnenden, 2019/05/01



<http://www.kaercher.com/dealersearch>

