

# 9450 / 9460

## Hot Water - Oil Fired Burner Modules

### Operator's Manual

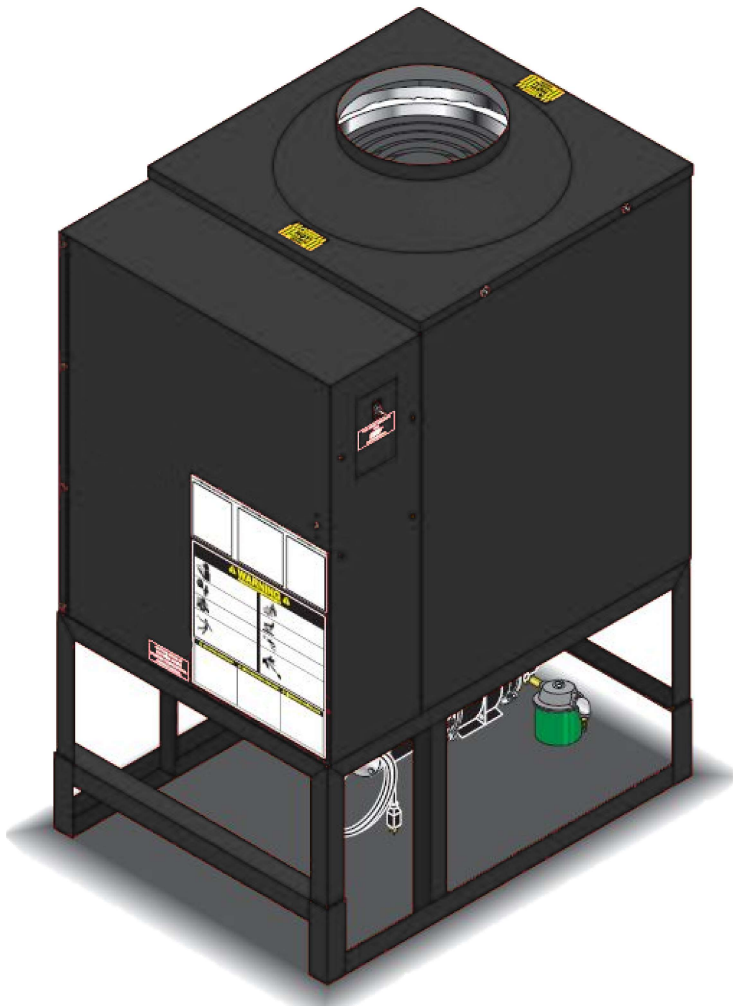

**MODELS:**

**9450**  
**1.103-905.0**

**9460**  
**1.103-907.0**

For the Dealer nearest you,  
consult our web page at  
[www.kaercher/us/.com](http://www.kaercher/us/.com)



Intertek

8.914-364.0-M



08/14/20

**Machine Data Label**

---

Model: \_\_\_\_\_

Date of Purchase: \_\_\_\_\_

Serial Number: \_\_\_\_\_

Dealer: \_\_\_\_\_

Address: \_\_\_\_\_

Phone Number: \_\_\_\_\_

Sales Representative: \_\_\_\_\_

**Machine Data Label . . . . . 2**  
**Table of Contents . . . . . 3**  
**How To Use This Manual . . . . . 4**

**Safety**

Introduction & Safety Information . . . . . 5  
IMPORTANT SAFETY INFORMATION . . . . . 6

**Operations**

Technical Specifications . . . . . 10  
Component Identification . . . . . 11  
Installation . . . . . 12  
Operation Instructions . . . . . 13  
Detergents & General Cleaning Techniques . . . . 14  
Shutting Down & Clean Up . . . . . 15

**Maintenance**

Preventative Maintenance . . . . . 16  
Winterizing Procedure . . . . . 16  
High Limit Thermostat . . . . . 16  
Cleaning of Coils . . . . . 16  
Delimiting Coils . . . . . 16  
Relief Valve . . . . . 17  
Fuel . . . . . 17  
Ignition Circuit . . . . . 17  
Electrode Setting . . . . . 17  
Burner Nozzle . . . . . 17  
Fuel Control System . . . . . 18  
Fuel Pressure Adjustment . . . . . 18  
Burner Air Adjustment . . . . . 18  
Maintenance Schedule . . . . . 19  
Oil Change Record . . . . . 19  
Troubleshooting . . . . . 20

**Parts**

9450 Left . . . . . 24  
9450 Right . . . . . 25  
Parts 9450 . . . . . 26  
Control Panel . . . . . 28  
9460 Left . . . . . 30  
9460 Right . . . . . 31  
Parts 9460 . . . . . 32  
PHW-Series Wayne Burner . . . . . 34  
Wiring Diagram . . . . . 36

## How To Use This Manual

This manual contains the following sections:

- How to Use This Manual
- Safety
- Operations
- Maintenance
- Parts List

The HOW TO USE THIS MANUAL section will tell you how to find important information for ordering correct repair parts.

Parts may be ordered from authorized dealers. When placing an order for parts, the machine model and machine serial number are important. Refer to the MACHINE DATA box which is filled out during the installation of your machine. The MACHINE DATA box is located on the inside of the front cover of this manual.

Model: _____
Date of Purchase: _____
Serial Number: _____
Dealer: _____
Address: _____
Phone Number: _____
Sales Representative: _____

The model and serial numbers will be found on a decal attached to the machine

The SAFETY section contains important information regarding hazardous or unsafe practices of the machine. Levels of hazards are identified that could result in product damage, personal injury, or severe injury resulting in death.

The OPERATIONS section is to familiarize the operator with the operation and function of the machine.

The MAINTENANCE section contains preventive maintenance to keep the machine and its components in good working condition. They are listed in this general order:

- Winterizing Procedure
- High Limit Thermostat
- Cleaning Of Coils
- Deliming Coils
- Removal Of Soot and Heating Coil
- Relief Valve
- Fuel
- Ignition Circuit
- Electrode Setting
- Burner Nozzle
- Fuel Control System
- Fuel Pressure Adjustment
- Burner Air Adjustment
- Maintenance Schedule
- Oil Change Record
- Troubleshooting

The PARTS LIST section contains assembled parts illustrations and corresponding parts list. The parts lists include a number of columns of information:

- **REF** – column refers to the reference number on the parts illustration.
- **PART NO.** – column lists the part number for the part.
- **QTY** – column lists the quantity of the part used in that area of the machine.
- **DESCRIPTION** – column is a brief description of the part.
- **NOTES** – column for information not noted by the other columns.

*NOTE: If a service or option kit is installed on your machine, be sure to keep the KIT INSTRUCTIONS which came with the kit. It contains replacement parts numbers needed for ordering future parts.*

*NOTE: The manual part number is located on the lower right corner of the front cover.*

## **Introduction & Safety Information**

Thank you for purchasing a heating module.

This manual covers the operation and maintenance of the 9450 and the 9460 oil fired heater modules. All information in this manual is based on the latest product information available at the time of printing.

We reserves the right to make changes at any time without incurring any obligation.

### **Owner/User Responsibility:**

The owner and/or user must have an understanding of the manufacturer's operating instructions and warnings before using this heating module. Warning information should be emphasized and understood. If the operator is not fluent in English, the manufacturer's instructions and warnings shall be read to and discussed with the operator in the operator's native language by the purchaser/owner, making sure that the operator comprehends its contents.

Owner and/or user must study and maintain for future reference the manufacturers' instructions.

### **SAVE THESE INSTRUCTIONS**

**This manual should be considered a permanent part of the machine and should remain with it if machine is resold.**

**When ordering parts, please specify model and serial number.**

## IMPORTANT SAFETY INFORMATION

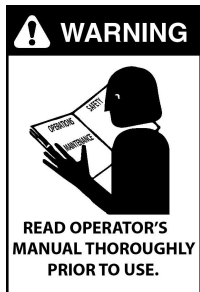

**WARNING:** To reduce the risk of injury, read operating instructions carefully before using.

**AVERTISSEMENT:** Pour réduire le risque de blessures, lire attentivement les instructions de fonctionnement avant l'utilisation.

1. Read the owner's manual thoroughly. Failure to follow instructions could cause malfunction of the machine and result in death, serious bodily injury and/or property damage.

Read owner's manual of attached pressure washer before operating.

2. Stay alert — watch what you are doing.
3. All installations must comply with local codes. Contact your electrician, plumber, utility company or the selling dealer for specific details. his product should be connected to a power supply protected by a GFCI. Use copper conductors only for electrical connections.



**WARNING:** Flammable liquids can create fumes which can ignite causing property damage or severe injury.

**AVERTISSEMENT:** Des liquides inflammables peuvent produire des vapeurs qui peuvent s'enflammer, causant ainsi des dommages à la propriété ou des blessures graves.

**WARNING:** Do not use gasoline, crankcase drainings or oil containing gasoline, solvents or alcohol. Doing so will result in fire and/or explosion.

**AVERTISSEMENT:** Ne pas utiliser d'essence, de drainage du carter de moteur ou d'essence contenant de l'huile, de solvants ou de l'alcool. Agir de la sorte risquerait de créer un incendie et/ou une explosion.



**WARNING:** Risk of Explosion. Do not spray flammable liquids. Operate only where an open flame or torch is permitted.

**AVERTISSEMENT:** Risque d'explosion Utiliser uniquement dans des endroits où l'utilisation d'une flamme nue ou d'une torche est permise.

4. This oil burning machine shall be installed only in locations where combustible dusts and flammable gases or vapors are not present.
5. In these oil burning models, use only kerosene, No. 1 home heating fuel, or diesel.



**DANGER:** Keep wand, hose, and water spray away from electric wiring or fatal electric shock may result.

**DANGER:** Garder la lance, le boyau et le jet d'eau à l'écart de tout câblage électrique ou des chocs électriques mortels pourraient survenir.

6. To protect the operator from electrical shock, the machine must be electrically grounded. It is the responsibility of the owner to connect this machine to a UL grounded receptacle of proper voltage and amperage ratings. Do not spray water on or near electrical components. Do not touch machine with wet hands or while standing in water. Always disconnect power before servicing.



**WARNING:** Spray gun kicks back — hold with both hands.

**AVERTISSEMENT:** Le pistolet pulvérisateur peut présenter un risque de retour; le tenir avec les deux mains.

7. Grip cleaning wand of the attached pressure washer securely with both hands before starting the cleaner. Failure to do this could result in injury from a whipping wand.



**WARNING:** High pressure stream of fluid from the pressure washer attached to this equipment can produce can pierce the skin and its underlying tissues, leading to serious injury and possible amputation. Keep clear of nozzle. Use caution when operating. Do not direct discharge stream at people or animals or severe injury or

death will result.

**AVERTISSEMENT:** Le jet de liquide haute pression de la laveuse à pression attaché à cet équipement peut percer la peau et ses tissus sous-jacents, causant ainsi des blessures graves et possiblement une amputation. Faire preuve de prudence lors de l'utilisation. Ne pas décharger directement le jet vers des personnes ou des animaux, car cela risquerait de causer des blessures graves ou même la mort.

- Never make adjustments on machine while it is in operation.



**WARNING:** High pressure spray can cause paint chips or other particles to become airborne and fly at high speeds.

**AVERTISSEMENT:** Un jet haute pression peut écailler la peinture ou provoquer l'émission d'autres particules dans l'air et leur projection à hautes vitesses.

- Always wear properly rated eye protection such as safety goggles or face shield while spraying. (Safety glasses do not provide full protection).

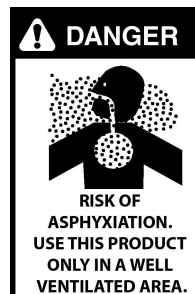

**DANGER:** Risk of asphyxiation. Use this product only in a well ventilated area.

**DANGER:** Risque d'asphyxie. Utiliser ce produit uniquement dans un endroit bien ventilé.

- When the machine is working, do not cover or place in a closed space where ventilation is insufficient.



**WARNING:** Risk of fire. Do not add fuel when the machine is operating or still hot.

**AVERTISSEMENT:** Risque d'incendie. Ne pas ajouter de carburant pendant que la machine fonctionne ou est encore chaude.

- Attached pressure washer with a spray gun should not be operated with the spray gun in the off position for extended periods of time as this may cause damage to the pump. Check to make sure burner shuts off when spray gun trigger is closed.



**WARNING:** Protect from freezing.

**AVERTISSEMENT:** Protéger la machine contre le gel.

- To prevent a serious injury, make certain quick coupler on discharge hose has locked before using pressure washer.
- Do not allow acids, caustic or abrasive fluids to pass through the pump.
- Inlet water must be from a cold, fresh, city water supply.
- Do not allow CHILDREN to operate the pressure washer at any time. THIS MACHINE MUST BE ATTENDED DURING OPERATION.
- The best insurance against an accident is precaution, and knowledge of the machine.
- Do not operate this product when fatigued or under the influence of alcohol or drugs. Keep operating We will not be liable for any changes made to our standard machines, or any components not purchased from us.
- Do not overreach or stand on unstable support. Keep good footing and balance at all times.
- Follow the maintenance instructions specified in the manual.

## Safety

21. When making repairs disconnect from electrical source.
22. Turn burner off and open spray gun to allow water to flow and cool coil to 100° before turning machine off.
23. Before disconnecting high pressure hose from 9450 or 9460 water outlet, open spray gun to relieve back pressure in hose.



**CAUTION: Hot discharge fluid. Do not touch or direct discharge stream at persons or animals.**

**AVERTISSEMENT: Liquide de décharge chaud. Ne pas toucher ou décharger directement le jet vers des personnes ou des animaux, car cela risquerait de causer des blessures graves ou**

**même la mort.**

**CAUTION: This machine produces hot water and must have insulated components attached to protect the operator.**

**AVERTISSEMENT: Cette machine produit de l'eau chaude et doit comporter des composants isolés attachés pour protéger l'opérateur.**



**WARNING: If connection is made to potable water supply, a back flow device must be provided.**

**AVERTISSEMENT: Si une connexion est établie avec un approvisionnement en eau potable, un dispositif de protection contre le retour d'eau doit être fourni.**



**WARNING: Do not spray machine or any people, animals or electrical parts.**

**AVERTISSEMENT: Ne pas vaporiser sur la machine ou les gens, les animaux ou les pièces électriques.**



**Follow the maintenance instructions specified in the manual.**





## Operations

---

### Technical Specifications

Model #	Maximum Inlet Pressure	Burner Type	Burner Fuel Pressure	Machine Voltage	Total Machine Amperage
9450	3200 PSI	Oil Fired 550,872 BTU/Hr. In	NOT TO EXCEED 200 PSI	120V	8 Amps
9460	3200 PSI	Oil Fired 720,603 BTU/Hr. In	NOT TO EXCEED 200 PSI	120V	8 Amps

Model #	Machine Weight	Shipping Weight	Exhaust Stacks Size	Machine Dimensions
9450	495 Lbs	525 Lbs	10"	L 32.5" X W 25" X H 50.5"
9460	865 Lbs	920 Lbs	12"	L 40.5" X W 32" X H 65"

**Component Identification**

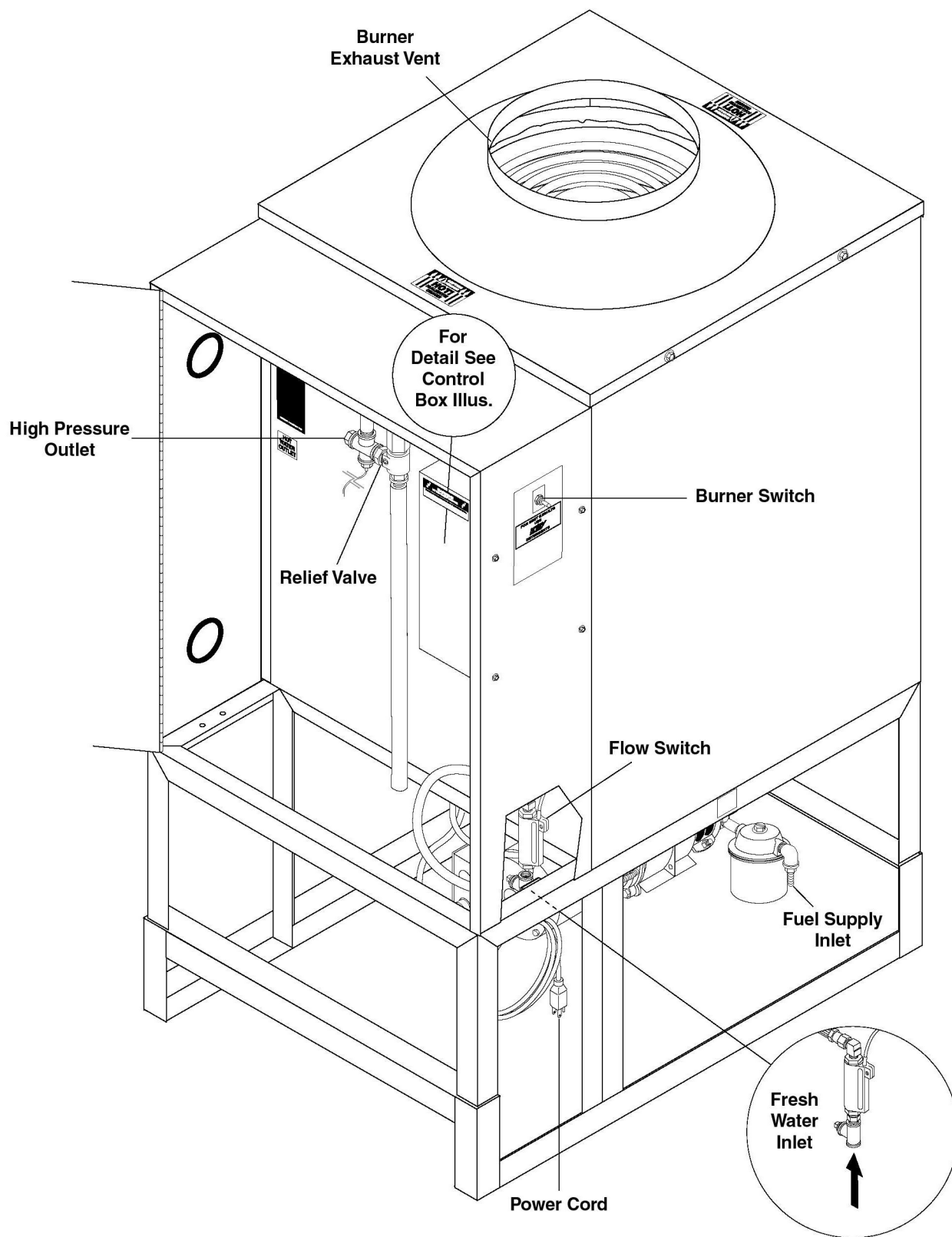

## Operations

### Installation

Place machine in a convenient location providing ample support, draining and room for maintenance.

### Location

The location should protect the machine from damaging environmental conditions such as wind, rain, and freezing temperatures.

### These machines are designed for indoor use. They must be stored indoors when not in use.

1. The machine should be run on a level surface where it is not readily influenced by outside sources such as strong winds, freezing temperatures, rain, etc. The unit should be located to allow accessibility for refilling of fuel, adjustments and maintenance. Normal precautions should be taken by the operator of the unit to prevent excess moisture from reaching the power unit or electrical controls.
2. It is recommended that a partition be made between the wash area and the machine to prevent direct water spray from coming in contact with the machine. Excess moisture reaching any electric components or electrical controls will reduce machine life and may cause electrical shorts.
3. During installation of the machine, beware of poorly ventilated locations or areas where exhaust fans may cause an insufficient supply of oxygen. Sufficient combustion can only be obtained when there is a sufficient supply of oxygen available for the amount of fuel being burned.

### Electrical

This machine, when installed, must be electrically grounded in accordance to local codes. Check for proper power supply using a volt meter.

**CAUTION: Use copper conductors only.**

**ATTENTION: Utiliser des conducteurs en cuivre seulement.**

### Placement

Install this machine about 2 feet from wall to provide adequate ventilation and servicing space. This equipment incorporates parts such as snap switches or similar parts that tend to produce arcs or sparks. Therefore, when located in a garage, it should be in a room or enclosure provided for the purpose or should be installed 18" (457mm) or more above the floor.

### Water Source

The water source for the machine should be supplied by a 5/8" I.D. garden hose with a city water pressure of not less than 30 psi. If the water supply is inadequate, or if the garden hose is kinked, the attached pressure washer will run very rough and the burner will not fire.

### Connection

Connect the wand, nozzle, hose and spray gun (where applicable). On pipe thread connections, use teflon tape to avoid water leaks.  
(See Component Identification.)

### Venting

Adding exhaust vent pipe to your oil fired burner is not recommended. It restricts air flow, causing carbon build-up, which affects the operation, and increases maintenance on the coil. If a stack must be used, refrain from using 90° bends. If the pipe can not go straight up then use only 45° bends and go to the next size pipe. The overall pipe length must not exceed 6 feet in length.

**Operation Instructions**

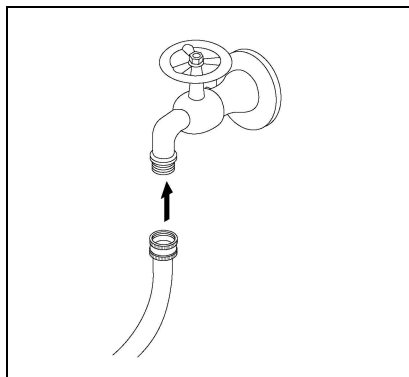

**STEP 1:** Review installation instructions prior to connecting water supply and checking fuel tank and pump oil level on both machines.

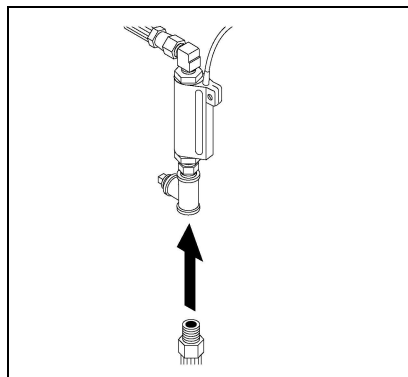

**STEP 2:** Connect high pressure hose from pressure washer (not included) to burner module.

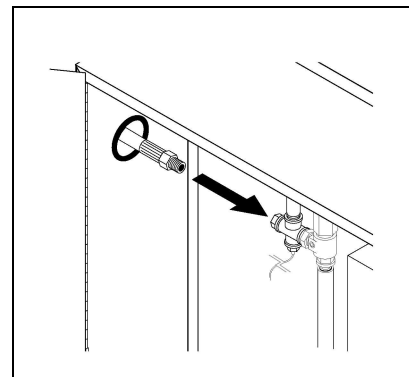

**STEP 3:** Connect high pressure hose from pressure washer when connecting to burner module outlet.

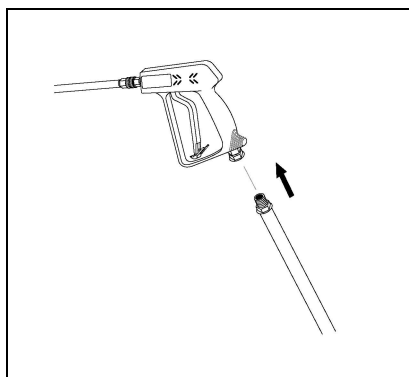

**STEP 4:** Attach high pressure wand to spray gun of connected pressure washer (Not Included).

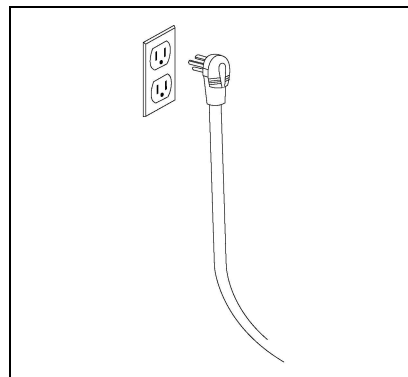

**STEP 5:** Connect the power cords into proper electrical outlet (See Serial Plate).

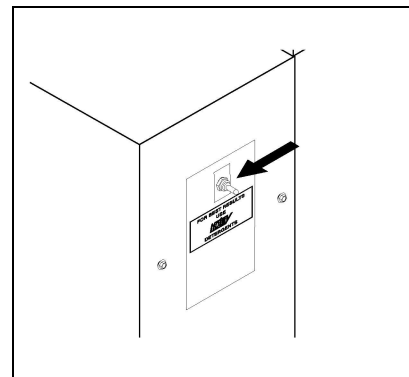

**STEP 6:** Turn on burner switch. Pilot ignition will begin to spark. Confirm pilot light ignition, if unsuccessful, turn off switch and turn on again. If pilot continues to spark, but not light, consult troubleshooting guide.

## Operations

### Detergents & General Cleaning Techniques

Refer to operation manual of machine that is to be connected to the oil fired heating module for instructions on applying detergent. Follow instructions when using detergent injectors from the supplier of the injector.

Pre-rinse cleaning surface with fresh water. Place detergent suction tube directly into cleaning solution and apply to surface at low pressure (for best results, limit your work area to sections approximately 6 feet square and always apply detergent from bottom to top). Allow detergent to remain on surface 1-3 minutes. Do not allow detergent to dry on surface. If surface appears to be drying, simply wet down surface with fresh water. If needed, use brush to remove stubborn dirt. Rinse at high pressure from top to bottom in an even sweeping motion, keeping the spray nozzle approximately 1 foot from cleaning surface. Use overlapping strokes as you clean and rinse any surface. For best surface cleaning action spray at a slight angle.

### Recommendations

- Before cleaning any surface, an inconspicuous area should be cleaned to test spray pattern and distance for maximum cleaning results.
- If painted surfaces are peeling or chipping, use extreme caution as pressure washer may remove the loose paint from the surface.
- Keep the spray nozzle a safe distance from the surface you plan to clean. High pressure wash a small area, then check the surface for damage. If no damage is found, continue to pressure washing.

#### **CAUTION - Never use:**

- Bleach, chlorine products and other corrosive chemicals
- Liquids containing solvents (i.e., paint thinner, gasoline, oils, etc.)
- Tri-sodium phosphate products
- Ammonia or Acid-based products

These chemicals will harm the machine and will damage the surface being cleaned.



#### **ATTENTION: Ne jamais utiliser:**

- Eau de Javel, produits à base de chlore et autres produits chimiques corrosifs
- Liquides contenant des solvants (c.-à-d. diluant à peinture, essence, huiles, etc.)
- Produits à base de tripolyphosphate de sodium
- Ammoniac ou produits à base d'acide

Ces produits chimiques endommageront la machine et endommageront la surface étant nettoyée.

### Rinsing

It will take a few seconds for the detergent to clear. Apply safety latch to spray gun. Select and install desired high pressure nozzle.

*NOTE: You can also stop detergent from flowing by removing detergent siphon tube from bottle.*

### Shutting Down & Clean Up

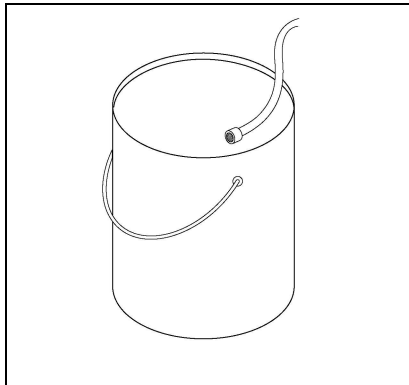

**STEP 1:** To clean detergent from hose and wand, insert end of detergent hose in clean bucket of water and run for a few minutes until steady stream of clean water is evident.

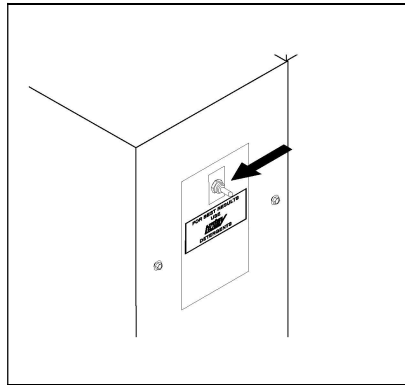

**STEP 2:** Turn Burner Switch "Off" and continue spraying water until temperature reaches 100°.

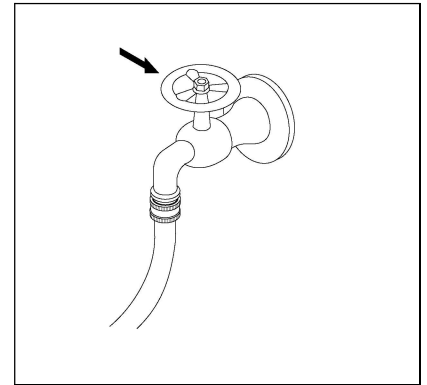

**STEP 3:** Turn water off.

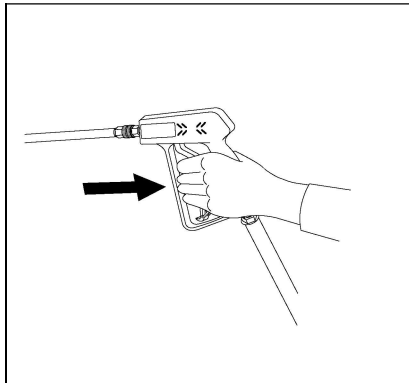

**STEP 4:** Open spray gun to relieve remaining pressure.

### Preventative Maintenance

1. Use clean fuel - kerosene, No. 1 home heating fuel or diesel. Clean or replace fuel filter every 100 hours of operation. Avoid water contaminated fuel as it will seize up the fuel pump. De-soot coils monthly. Use an additive if diesel is being used.
2. Check to see that the attached pressure washer water pump is properly lubricated.
3. Follow **Winterizing Procedures** to prevent freeze damage to pump and coils.
4. Always neutralize and flush chemical from system after use.
5. If water is known to be high in mineral content, use a water softener on your water system, or de-scale as needed.
6. Do not allow acidic, caustic or abrasive fluids to be pumped through system.
7. Always use high grade quality cleaning products.
8. Never run attached pressure washer pump dry for extended periods of time.
9. If machine is operated with smoky or eye burning exhaust, coils will soot up, not letting water reach maximum operating temperature. (See section on Air Adjustments).
10. Never allow water to be sprayed on or near the motor or burner assembly or any electrical component.
11. Delime coils per instructions.

It is advisable, periodically, to visually inspect the burner. Check air inlet to make sure it is not clogged or blocked. Wipe off any oil spills and keep this equipment clean and dry.

The areas around the washer should be kept clean and free of combustible materials, gasoline and other flammable vapors and liquids.

The flow of combustion and ventilating air to the burner must not be blocked or obstructed in any manner.

### Maintenance And Service

#### Winterizing Procedure

Damage due to freezing is not covered by warranty. Adhere to the following cold weather procedures whenever the washer must be stored or operated outdoors under freezing conditions.

During winter months, when temperatures drop below 32°F, protecting your machine against freezing is necessary. Store the machine in a heated room. If this is not possible, use compressed air to blow all water out of the system.

#### High Limit Thermostat

For safety, each machine is equipped with a high limit control switch. In the event the temperature of the water should exceed its operating temperature the high limit control will turn the burner off until the water cools.

#### Cleaning of Coils

In alkaline water areas, lime deposits can accumulate rapidly inside the coil pipes. This growth is increased by the extreme heat build up in the coil. The best prevention for liming conditions is to use high quality cleaning chemicals. In areas where alkaline water is an extreme problem, periodic use of Deliming Powder will remove lime and other deposits before coil becomes plugged.

#### Deliming Coils

Periodic flushing of coils or optional float tank is recommended.

**Step 1** Fill a container or float tank with 4 gallons of water, then add 1 lb. of deliming powder. Mix thoroughly. Verify mixing ratio on deliming powder package.

**Step 2** Remove nozzle from wand assembly and put spray gun and wand assembly into float tank. Attach a nylon stocking to the end of the wand to collect debris.

**Step 3** Attach a short section (3-5 ft.) of garden hose to the attached pressure washer to siphon solution from an elevated container. Turn attached pressure washer switch on, allowing solution to be pumped through coils back into the container. Solution should be allowed to circulate 2-4 hours.

**Step 4** After circulating solution flush entire system with fresh water. Reinstall high pressure nozzle into wand.



## Removal of Soot and Heating Coil

In the heating process, fuel residue in the form of soot deposits may develop between the heating coil pipe and block air flow which will affect burner combustion. When soot has been detected on visual observation, the soot on the coil must be washed off after following the coil removal steps.

## Relief Valve

**WARNING:** The relief valve on this pressure washer has been factory set and sealed and is a field nonadjustable part. Tampering with the factory setting may cause personal injury and/or property damage and will void the manufacturer warranty. For replacement parts refer to exploded views.

**AVERTISSEMENT:** La soupape de décharge sur cette laveuse à pression a été réglée en usine, puis scellée, et est une pièce non réglable. L'altération du paramètre de l'usine pourrait causer des lésions corporelles et/ou des dommages à la propriété, et annulera la garantie du fabricant. Pour des pièces de rechange, se référer aux vues éclatées.

**This safety valve must be inspected and tested annually.**

## Fuel

Use clean fuel oil that is not contaminated with water and debris. Replace fuel filter and drain tank every 100 hours of operation.

Use No. 1 or No. 2 Heating Oil (ASTM D306) only. **NEVER** use gasoline in your burner tank. Gasoline is more combustible than fuel oil and could result in a serious explosion. **NEVER** use crankcase or waste oil in your burner. Fuel unit malfunction could result from contamination.

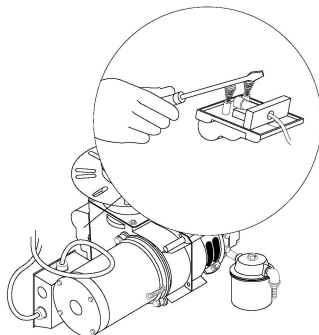

## Ignition Circuit

Periodically inspect wires, spring contact and electrodes for condition, security and proper spacing. Transformer test:

**(CAUTION 10,000 VOLTS)** use defect free insulated screwdriver and keep fingers off blade! Lay blade across one contact: OK if arc will span 1/2" between end of blade and other contact.

## Electrode Setting

### Gun Setting Instructions

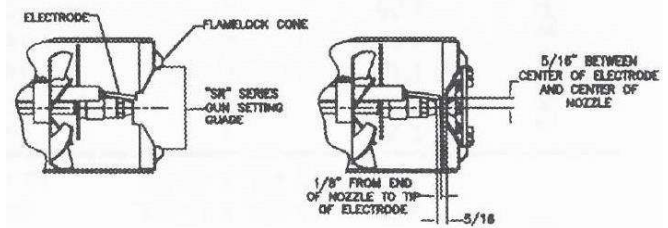

(For EHASR Only)

**SR-Series gage KNA Part Number 8.717-379.**

## Burner Nozzle

Keep the tip free of surface deposits by wiping it with a clean, solvent-saturated cloth, being careful not to plug or enlarge the nozzle. For maximum efficiency, replace the nozzle each season.

### Fuel Control System

The 9450 and 9460 both utilize a fuel solenoid valve located on the fuel pump to control the flow of fuel to the combustion chamber. This solenoid, which is normally closed, is activated by a flow switch when water is flowing through it. When an operator releases the trigger on the spray gun, the flow of water through the flow switch stops, turning off the current to the fuel solenoid. The solenoid then closes, shutting off the supply of fuel to the combustion chamber. Controlling the flow of fuel in this way gives an instantaneous burn or no burn situation, thereby eliminating high and low water temperatures, and combustion smoke normally associated with machines incorporating a spray gun. Periodic inspection is recommended to insure that the fuel solenoid valve functions properly. This can be done by operating the machine and checking to see that when the trigger on the spray gun is in the off position, the burner is not firing.

### Fuel Pressure Adjustment

To adjust fuel pressure, First install a pressure gage into the port just after the pump fuel exit. Turn the adjusting screw (located at the regulator port) clockwise to increase, and counterclockwise to decrease. Do not exceed 200 psi or lower the pressure below 130 PSI, when checked at the post-pump pressure port.

The fuel pressure may need to be adjusted due to altitude. For every 500 ft altitude above sea level, the boiling point of water goes down 1 °F. At high altitude environments, this boiling point change may require the heat input to be lowered so the water input does not turn to steam earlier than at the factory settings and activate the pressure sensors and pressure relief equipment when the unit is operated and much higher altitudes from factory settings or local dealer site settings. Check with your dealer before making local site fuel pressure adjustments.

Also, as ambient temperature changes seasonally, the fuel temperature in the feed tank and air temperature inlet can impact fuel flow. In more extreme temperatures, this local-site adjustment may also require different fuel nozzles for fuel inlet temperatures that are at seasonal extremes (higher or lower) in locations where the temperature changes are beyond moderate temperatures of between 40°F and 90°F. Colder temperatures will make for a thicker flow and less fine a fuel spray while hotter temperatures will make for a thinner flow a more fine spray with the same nozzle. Consider alternate nozzle configurations from the

baseline factory-supplied nozzle for operating in such temperature extremes if performance is not meeting needs with air band and fuel pressure settings alone.

*NOTE: When changing fuel pump, a by-pass plug must be installed in return line port or fuel pump will not prime.*

### Burner Air Adjustment

The oil burner on this machine is preset for operation at altitudes below 500 feet. If operated at higher altitudes, it may be necessary to adjust the air band for a #1 or #2 smoke spot on the Bacharach scale.

To adjust, start machine and turn burner ON. Loosen two locking screws found on the air band and close air band until black smoke appears from burner exhaust vent. Note air band position. Next, slowly open the air band until white smoke just starts to appear. Turn air band halfway back to the previously noted position. Tighten locking screws.

For higher altitudes, the air band opening may need to be increased; for lower altitude, the air band may need to be decreased.

For higher humidity, the air band opening may need to be increased; for lower relative humidity, the air band may need to be decreased.

For higher ambient temperatures the air band opening may need to be increased; for lower ambient temperatures, the air band opening may need to be decreased.

Adjust to your operating location's environment as-needed for best smoke spot and performance compliant with local, state, and federal regulations.

**Maintenance Schedule**

This Burner Module was produced with the best available materials and quality craftsmanship. However, you as the owner have certain responsibilities for the correct care of the equipment. Attention to regular preventative maintenance procedures will assist in preserving the performance of your equipment. Contact your dealer for maintenance. Regular preventative maintenance will add many hours to the life of your pressure washer. Perform maintenance more often under severe conditions.

**Follow operators manual from the pressure washer manufacture that is connected to the Burner Module.**

<b>MAINTENANCE SCHEDULE</b>	
Remove Burner Soot From Heating Coil	Annually
Descale Coil	Annually - (more often if required)
Replace Quick Connects	Annually
Clean Water and Detergent Screen/Filter	Weekly
Clean Float/Supply Tank	Every 6 months
Replace HP Hose	If there is any sign of wear
Grease Motor	Every 10,000 hours
Check Burner Pilot Jets	Annually
Pressure Relief Valve	Annually

**Oil Change Record**

<b>Date Oil Changed Month/Day/Year</b>	<b>Estimated Operating Hours Since Last Oil Change</b>

## Maintenance

### Troubleshooting

PROBLEM	POSSIBLE CAUSE	SOLUTION
<b>BURNER WILL NOT LIGHT</b>	Flex coupling slipping on fuel pump shaft or burner motor shaft	Replace if needed.
	On-Off switch defective	Check for electrical current reaching burner assembly with burner switch on.
	Heavy sooting on coil and burner can cause interruption of air flow and shorting of electrodes	Clean as required.
	Improper electrode setting	Check and reset according to diagram in Operator's Manual.
	Fuel not reaching combustion chamber	Check fuel pump for proper flow. Check solenoid flow switch on machines with spray gun control, for proper on-off fuel flow control.
	Clogged burner nozzle	Clean as required.
	Thermostat faulty or slow engine speed	Increase engine RPM to increase voltage.
	Flow switch malfunction	Remove, test for continuity and replace as needed.
	Flow solenoid malfunction	Replace if needed.
	Disconnected or short in electrical wiring	All wire contacts should be clean and tight. No breaks in wire.
	Little or no fuel	Fill tank with fuel.
	Improper fuel or water in fuel	Drain fuel tank and fill with proper fuel.
	Clogged fuel line	Clean or replace.
	Plugged fuel filter	Replace as needed.
	Misadjusted burner air bands	Readjust air bands for clean burn.
<b>MACHINE SMOKES WHILE BURNER UNIT IS RUNNING OR UNIT SMOKES AT COLD-START ONLY WHEN BURNER IS OFF</b>	Little or no fuel pressure from fuel pump	Increase fuel pressure to specification and/or replace fuel pump. Test with pressure gauge.
	Faulty burner transformer	Test transformer for proper arc between contacts. Replace as needed.
	Improper fuel or water in fuel	Drain tank and replace contaminated fuel
	Improper air adjustment	Readjust air bands on burner assembly
	Fuel pressure is low <140 psi for burner	Adjust fuel pump pressure to specifications
	Burner nozzle is plugged or dirty	Replace nozzle. Check parts breakdown for nozzle size
	Burner nozzle spray pattern is faulty	Replace nozzle. Check parts breakdown for nozzle size
	Heavy accumulation of soot on coils and burner assembly	Remove coils and burner assembly, clean thoroughly Call local dealer
	Misaligned electrode setting	Realign electrodes to specifications
	Obstruction in smoke stack	Check for insulation blockage or other foreign objects
Low engine RPM	Increase RPM to correct specs. See serial plate	
Improper burner nozzle	See exploded view parts list	

<b>PROBLEM</b>	<b>POSSIBLE CAUSE</b>	<b>SOLUTION</b>
<b>MACHINE SMOKES WHILE BURNER UNIT IS RUNNING OR UNIT SMOKES AT COLD-START ONLY WHEN BURNER IS OFF CONTINUED</b>	Fuel Pressure is too high for clean burn (fuel PSI above 140 and below 200) and smokes when burner is off	Reduce fuel pressure PSI/Increase air band set for cleaner without max water heat loss
<b>LOW WATER TEMPERATURE</b>	Improper fuel or water in fuel	Drain fuel tank and replace with proper fuel.
	Low fuel pressure	Increase fuel pressure.
	Weak fuel pump	Check fuel pump temperature. Replace pump if needed.
	Fuel filter partially clogged	Replace as needed.
	Soot build up on coils	Clean coils with soot remover.
	Lime build up on coils	Clean inside of coils using coil cleaner.
	Improper burner nozzle	See Burner Specifications.
<b>WATER TEMPERATURE TOO HOT</b>	Incoming water to machine warm or hot	Lower incoming water temperature.
	Fuel pump pressure too high	Lower fuel pressure.
	Fuel pump defective	Replace fuel pump.
	Detergent line sucking air	Tighten all clamps. Check detergent line for holes.
	Defective high limit switch (thermostat)	Replace.
	Incorrect fuel nozzle size	See Burner Specifications.
	Insufficient water supplied	Check GPM to machine.
	Restricted water flow	Check nozzle for obstruction, proper size.



# Parts

**(1.103-905.0, 1.103-907.0)**

**9450 / 9460**

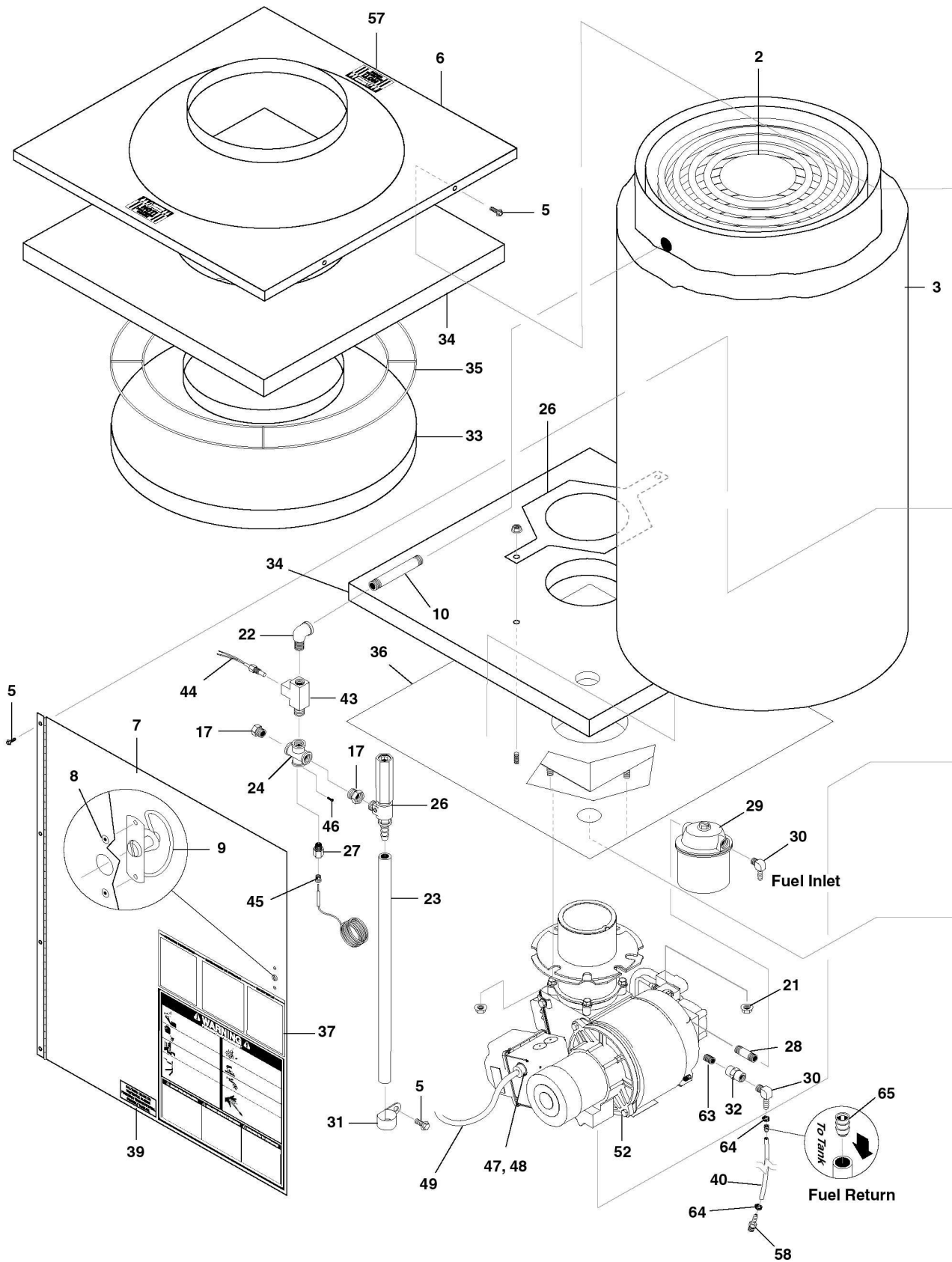



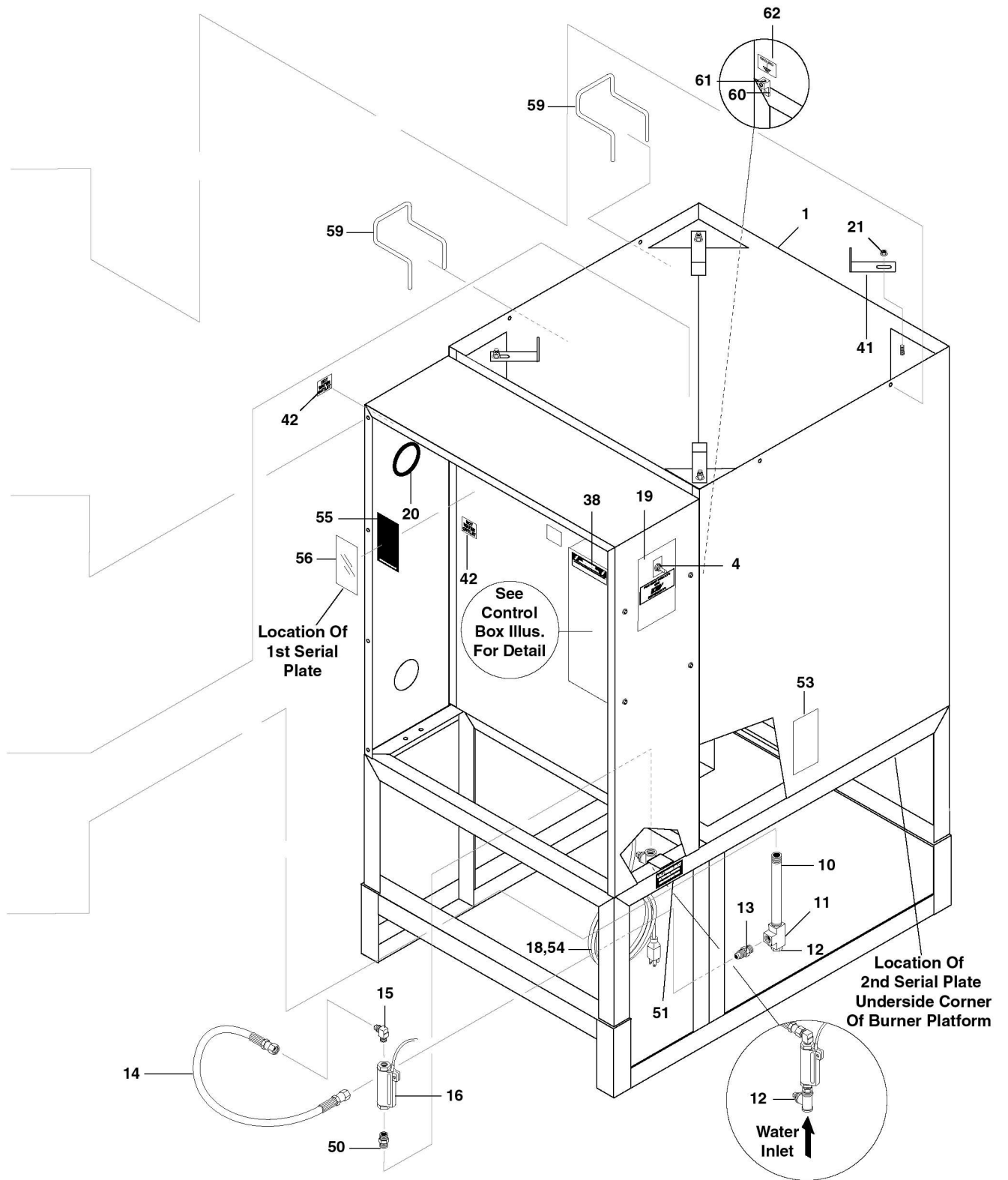

## Parts 9450

REF	PART NO.	QTY	DESCRIPTION	NOTES
1	8.911-482.0	1	CHASSIS PAINT	
2	8.911-494.0	1	COIL, OIL 22", WELDMENT	
3	8.717-452.0	6 ft.	INSULATION, CERAFELT	
4	8.716-112.0	1	SWITCH, TOGGLE, 10A/250V	
5	8.718-942.0	8	SCREW, #12 X 3/4", TEX	
6	8.911-600.0	1	LID, 24" PAINTED	
7	8.911-552.0	1	DOOR HEATER PAINT	
8	9.804-301.0	2	RIVET, 1/8" X 1/4", POP	
9	8.719-081.0	1	LATCH, SPRING FLUSH HEAD	
10	8.757-232.0	2	NIPPLE STEEL 1/2 NPTF X 4 W/SLNT	
11	8.757-615.0	1	TEE STEEL 1/2" NPTF (F)	
12	8.757-625.0	2	PLUG 1/2 NPTF SQUARE HEAD	
13	8.757-508.0	1	ADAPTER STEEL 1/2 SAE (M) X 1/2 NPTF (M)	
14	8.918-225.0	1	HOSE, 1/2" X 28", 2 WIRE, PRESSURE	
15	8.757-616.0	1	ADAPTER 1/2 JIC (M) X 3/8 BSPP (M) 90°	
16	8.933-006.0	1	SWITCH, 6- FLOW MV60, YELLOW	
17	8.757-513.0	2	BUSHING, 1/2"NPTF(M) X 3/8"NPTF(F),STEEL	
18	8.717-010.0	1	CORDSET, 115V/15A 5-15PX60	
19	8.900-898.0	1	LABEL, CONTROL PANEL	
20	8.706-548.0	1	GROMMET, 2-1/8" X 2-7/8"X7/16"	
21	9.802-778.0	10	NUT, WHIZ LOC 5/16" FLANGE	
22	8.757-991.0	1	ELBOW STREET STEEL 1/2 NPTF	
23	8.711-785.0	36"	HOSE, 3/8", PUSH-ON	
24	8.757-704.0	1	CROSS FEMALE STEEL 1/2"	
25	9.802-433.0	1	VALVE, SAFETY RELIEF, VSP	
26	8.912-016.0	1	BRACKET, INSULATION RETAINER	
27	8.757-989.0	1	ADAPTER STEEL 1/2 NPTF (M)X1/2 NPTF (F)	
28	8.757-366.0	1	NIPPLE, 1/4" X 3", W/SLNT	
29	8.749-771.0	1	FUEL FILTER/WATER SEP ASSY	
-	8.749-770.0	1	ELEMENT, FUEL FILTER/ WATER SEP	
30	8.757-205.0	2	HOSE BARB, 1/4" BARB x 1/4" M-NPTF, 90°	
31	9.802-207.0	1	CLAMP, WIRE/TUBE, 0.687 DIA	
32	8.757-990.0	1	COUPLING HEX BRASS 1/4 NPTF (F)	
33	8.911-598.0	1	LID, 22-1/2"	(9450 OIL FIRED ONLY)
34	8.717-451.0	2	INSULATION, 24" X 24" X 1/2"	
35	8.719-940.0	1	INSULATION, RETAINER RING	
36	8.911-630.0	1	BURNER MOUNT	
37	8.900-894.0	1	DECAL, OPERATING INSTRUCTION	
38	9.800-016.0	1	LABEL, WARNING DISCONNECT	
39	8.901-135.0	1	LABEL, WINTERIZE	
40	9.802-254.0	12"	HOSE, 1/4" PUSH-ON	
41	8.911-438.0	4	BRACKET, COIL	
42	9.800-021.0	2	LABEL, HOT WATER OUTLET	

REF	PART NO.	QTY	DESCRIPTION	NOTES
43	8.757-512.0	1	TEE, STREET, 1/2", STEEL	
44	8.712-185.0	1	SWITCH, SNAP	
45	8.707-286.0	1	WELL, THERMOSTAT	
46	9.804-568.0	1	SCREW, 6/32" X 3/8"	
47	9.802-515.0	1	STRAIN RELIEF	
48	9.802-525.0	1	LOCKNUT, 1/2"	
49	8.925-645.0	1	HARNESS CORD BURNER 9450	
50	8.757-992.0	1	ADAPTER STEEL 3/8 BSPP (M)X1/2 NPTF (M)	
51	9.800-020.0	1	LABEL, COLD WATER INLET	
52	8.756-921.0	1	BURNER, EH 1.75 120V 1T 120V S	
53	9.800-002.0	1	LABEL, USE ONLY KEROSENE	
54	8.932-969.0	1	LABEL, WARNING SERVICE CORD	
55	8.932-968.0	1	LABEL, OUTDOOR USE	
56	9.800-034.0	1	LABEL, CLEAR LEXAN	
57	9.800-006.0	2	LABEL, CAUTION HOT	
58	8.706-959.0	1	HOSE BARB, 1/4" BARB X 1/4" BARB, DOU	
59	8.719-946.0	2	HANGER, HOSE	
60	8.718-945.0	1	SCREW, #14 TEK	
61	8.716-460.0	1	LUG, GROUNDING	
62	9.800-040.0	1	LABEL, GROUND SYMBOL	
63	8.757-795.0	1	NIPPLE HEX BRASS 1/4 NPTF	
64	8.709-069.0	2	CLAMP, SCREW, 5/16"W, 1/4-5/8"D, SS	
65	8.754-911.0	1	CHECK VALVE, 1 WAY, 1/4" BARB	
66	8.754-893.0	1	FUEL NOZZLE 3.25 X 80 B W/PSI CHECK VALVE	9450 ONLY

## Control Panel

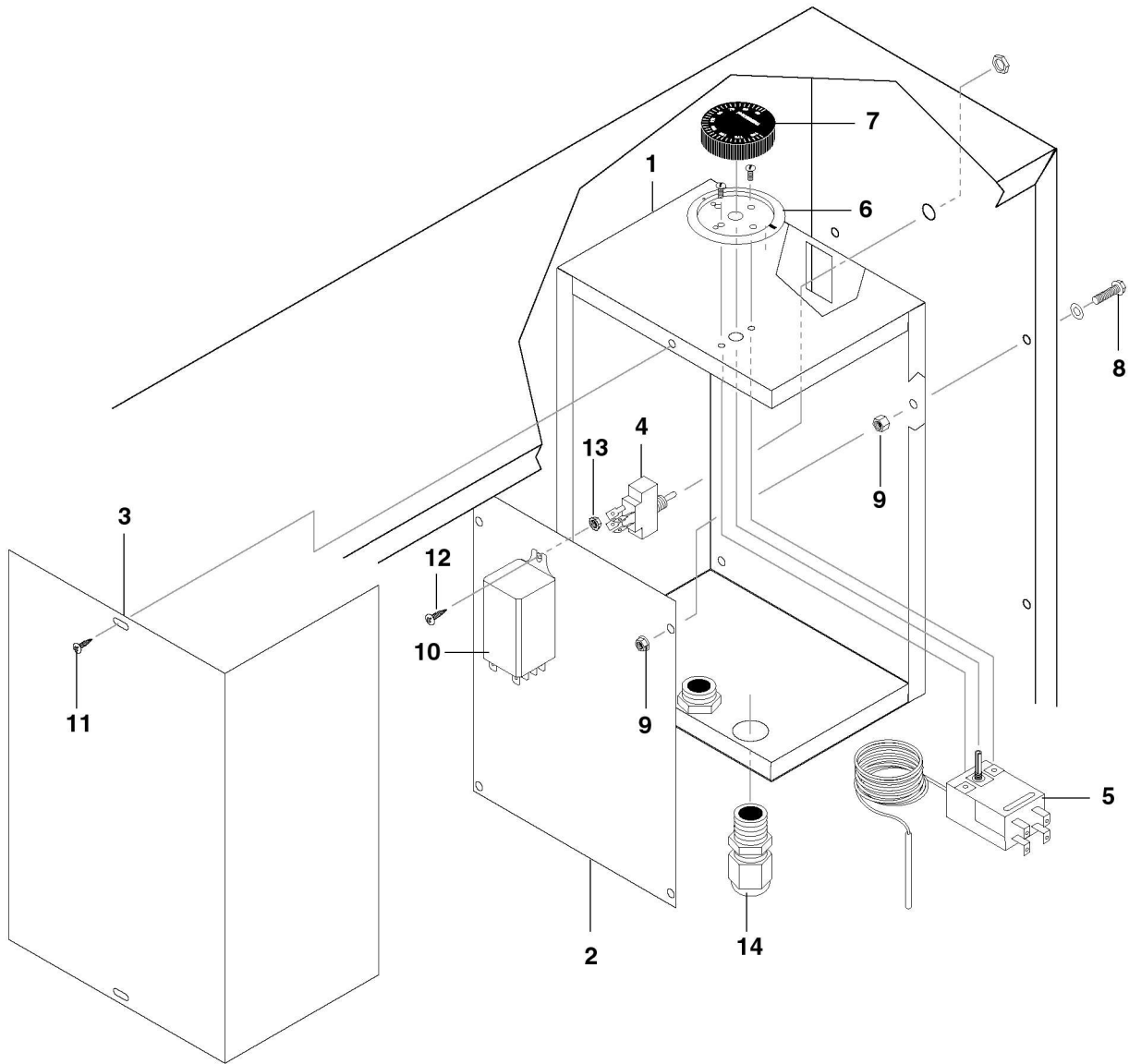

REF	PART NO.	QTY	DESCRIPTION	NOTES
1	8.911-773.0	1	BOX, ELECTRICAL	
-	9.802-103.0	1	BUSHING, 5/8" SNAP	NOT SHOWN
-	9.802-105.0	1	PLUG, 7/8", HOLE	NOT SHOWN
2	8.911-774.0	1	PLATE, STAND-OFF	
3	8.911-775.0	1	COVER, ELEC, BOX	
4	8.716-112.0	1	SWITCH, TOGGLE, 10A/250V	
5	8.712-191.0	1	THERMOSTAT, W/ONE METER CAPILLARY	
6	8.712-190.0	1	PLATE, THERMOSTAT PLASTIC COVER	
7	8.712-189.0	1	KNOB, THERMOSTAT 32-248°	
8	9.802-700.0	4	BOLT, 1/4" X 3/4", NC HH	
9	9.802-775.0	8	NUT, 1/4" FLANGE, ZN	
10	8.716-088.0	1	RELAY	
11	9.802-798.0	2	SCREW, #10 X 1/2", PHILLIPS, ZINC	
12	9.802-771.0	4	SCREW, 10-32 X 3/4"	
13	9.802-696.0	4	NUT, 10/32"	
14	9.802-514.0	3	STRAIN RELIEF, STRT, LQ TITE	

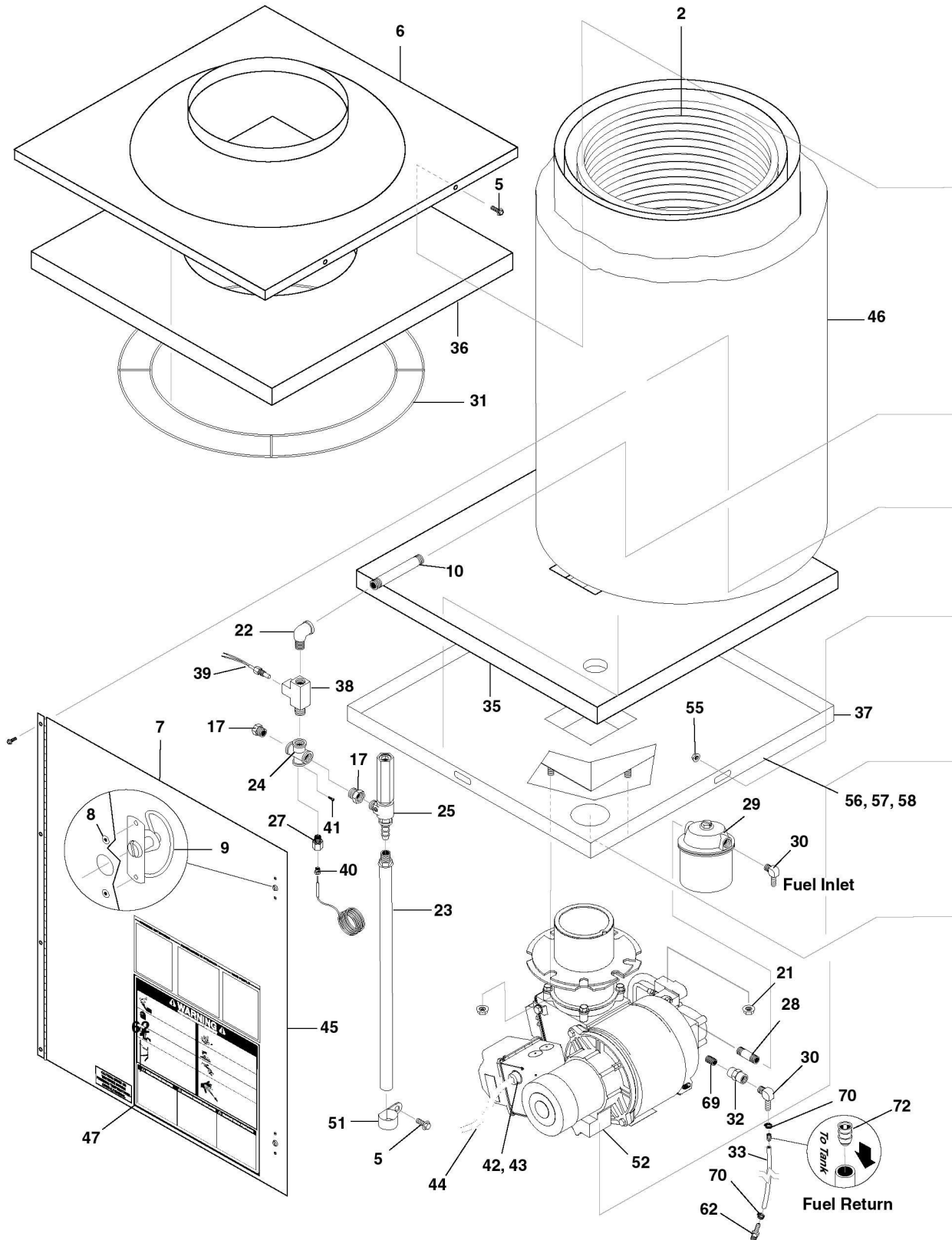

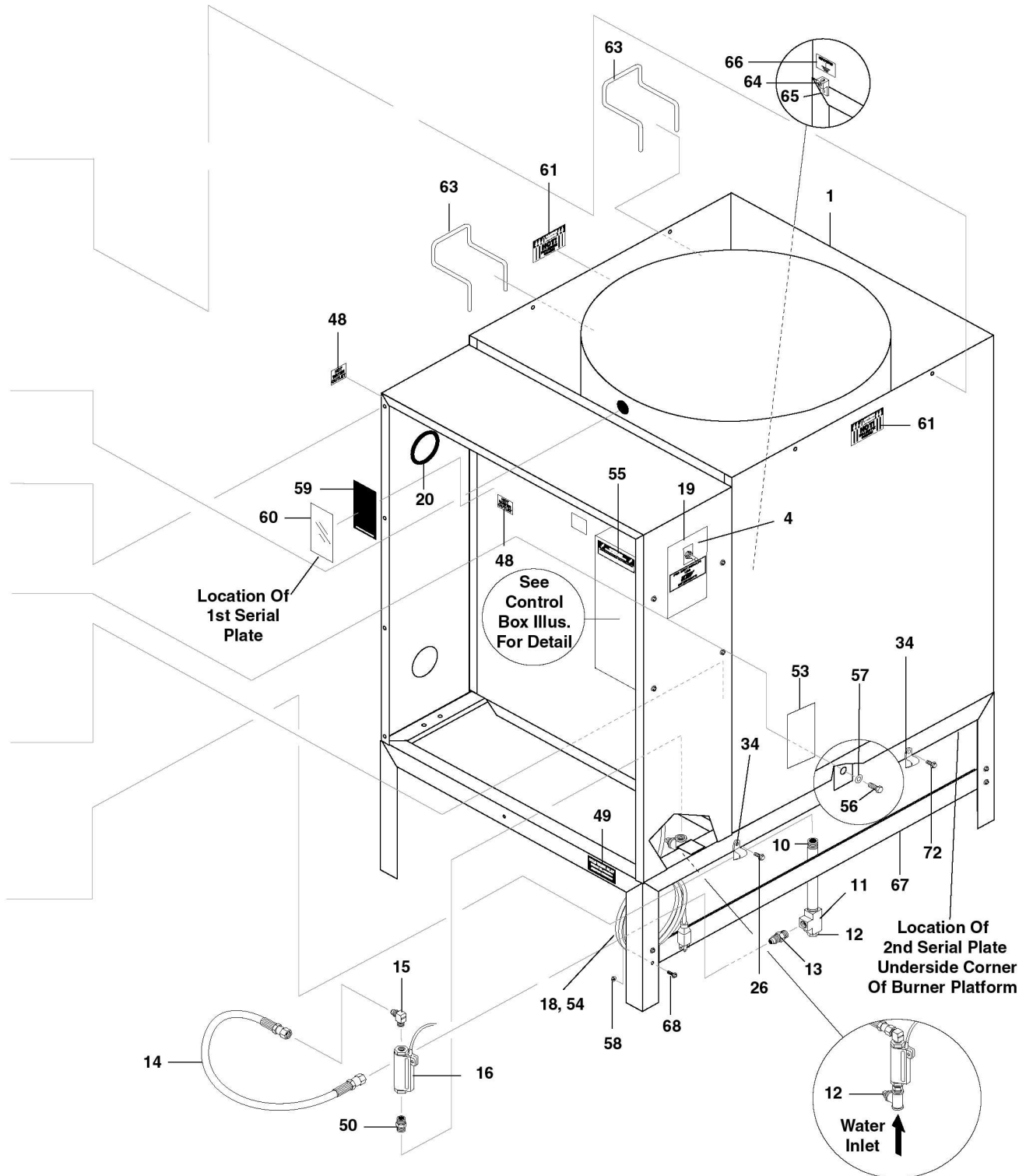

## Parts 9460

REF	PART NO.	QTY	DESCRIPTION	NOTES
1	8.911-481.0	1	CHASSIS PAINT	
2	8.911-496.0	1	COIL, GAS/OIL 28", WELDMENT	
3	8.717-451.0	1	INSULATION, CERFELT, 1/2" X 24 X 4.166SF	
4	8.716-112.0	1	SWITCH, TOGGLE, 10A/250V	
5	9.802-798.0	10	SCREW, #10 X 1/2" TEK	
6	8.911-601.0	1	LID 30" PAINTED, 9460	
7	8.911-551.0	1	DOOR HEATER PAINT, 9460	
8	9.804-301.0	4	RIVET, 1/8" X 1/4", POP	
9	8.719-081.0	2	LATCH, SPRING FLUSH HEAD	
10	8.757-232.0	2	NIPPLE STEEL 1/2 NPTF X 4 W/SLNT	
11	8.757-615.0	1	TEE STEEL 1/2" NPTF (F)	
12	8.757-625.0	2	PLUG 1/2 NPTF SQUARE HEAD	
13	8.757-508.0	1	ADAPTER STEEL 1/2 SAE (M) X 1/2 NPTF (M)	
14	8.918-230.0	1	HOSE, 1/2" X 70", 2 WIRE, PRESSURE	
15	8.757-616.0	1	ADAPTER 1/2 JIC (M) X 3/8 BSPP (M) 90°	
16	8.933-006.0	1	SWITCH, FLOW MV60, YELLOW	
17	8.757-513.0	2	BUSHING, 1/2"NPTF(M) X 3/8"NPTF(F),STEEL	
18	8.717-010.0	1	CORDSET, 115V/15A 5-15PX60	
19	8.900-898.0	1	LABEL, CONTROL PANEL	
20	8.706-548.0	1	GROMMET, 2-1/8" X 2-7/8" X 7/16"	
21	9.802-778.0	4	NUT, WHIZ LOC 5/16" FLANGE	
22	8.757-991.0	1	ELBOW STREET STEEL 1/2 NPTF	
23	8.711-785.0	44"	HOSE, 3/8", PUSH-ON	
24	8.757-704.0	1	CROSS FEMALE STEEL 1/2"	
25	9.802-433.0	1	VALVE, SAFETY RELIEF, VSP	
26	8.718-945.0	2	SCREW, #14 X 3/4" TEK	
27	8.757-989.0	1	ADAPTER STEEL 1/2 NPTF (M)X1/2 NPTF (F)	
28	8.757-366.0	1	NIPPLE, 1/4" X 3", W/SLNT	
29	8.749-771.0	1	FUEL FILTER, WATER SEP ASSY	
-	8.749-770.0	1	ELEMENT FUEL FILTER	NOT SHOWN
30	8.757-199.0	2	HOSE BARB, 1/4" BARB x 1/4" M-NPTF,BRASS	
31	8.719-936.0	1	INSULATION RETAINER RING	
32	8.757-990.0	1	Coupling hex brass 1/4 NPTF (F)	
33	9.802-254.0	12"	HOSE, 1/4" PUSH-ON	
34	8.709-091.0	2	CLIP, 1.25 ID ROUND	
35	8.717-451.0	1	INSULATION, 24" X 24"	
36	8.717-451.0	1	INSULATION, 30" X 30"	
37	8.911-608.0	1	MOUNT, BURNER	
38	8.757-512.0	1	TEE, STREET, 1/2", STEEL	
39	8.712-185.0	1	SWITCH, SNAP	
40	8.707-286.0	1	WELL, THERMOSTAT	
41	9.804-568.0	1	SCREW, 6/32" X 3/8"	



REF	PART NO.	QTY	DESCRIPTION	NOTES
42	9.802-515.0	1	STRAIN RELIEF	
43	9.802-525.0	1	LOCKNUT, 1/2"	
44	8.925-603.0	1	HARNESS CORD BURNER 9460	
45	8.900-894.0	1	DECAL, OPERATING INSTRUCTION	
46	8.717-451.0	8 ft.	INSULATION, CERFELT, 1/2" X 24"	
47	8.901-135.0	1	LABEL, WINTERIZE	
48	9.800-021.0	2	LABEL, HOT WATER OUTLET	
49	9.800-020.0	1	LABEL, COLD WATER INLET	
50	8.757-992.0	1	ADAPTER STEEL 3/8 BSPP (M)X1/2 NPTF (M)	
51	9.802-207.0	1	CLAMP, ROUND, .56 ID	
52	8.756-921.0	1	BURNER, EH 1.75 120V 1T 120V S	
53	9.800-002.0	1	LABEL, USE ONLY KEROSENE	
54	8.932-969.0	1	LABEL, WARNING, SERVICE CORD	
55	9.800-016.0	1	LABEL, WARNING ELECTRICAL	
56	8.718-618.0	3	BOLT, 5/16" X 3/4"	
57	8.718-980.0	3	WASHER, 5/16" FLAT	
58	9.802-778.0	11	NUT, 5/16" WHIZ LOC	
59	8.932-968.0	1	LABEL, OUTDOOR USE ONLY	
60	9.800-034.0	1	LABEL, LEXAN	
61	9.800-006.0	2	LABEL, CAUTION HOT	
62	8.706-959.0	1	HOSE BARB, 1/4" BARB X 1/4" BARB, DOU	
63	8.719-946.0	2	HANGER, HOSE	
64	8.718-945.0	1	SCREW, #14 X 3/4" TEK	
65	8.716-460.0	1	LUG, GROUNDING	
66	9.800-040.0	1	LABEL, GROUND SYMBOL	
67	8.911-626.0	2	BRACKET, LIFT	
68	9.803-551.0	1	SCREW, 5/16" X 3/4" WHIZ	
69	8.757-795.0	1	NIPPLE HEX BRASS 1/4 NPTF	
70	8.709-069.0	2	CLAMP, SCREW, 5/16"W, 1/4-5/8"D, SS	
71	8.755-049.0	1	FUEL NOZZLE 4.00 X 80 B W/PSI CHECK VALVE	9460
72	8.754-911.0	1	CHECK VALVE, 1 WAY, 1/4" BARB	

**PHW-Series Wayne Burner**

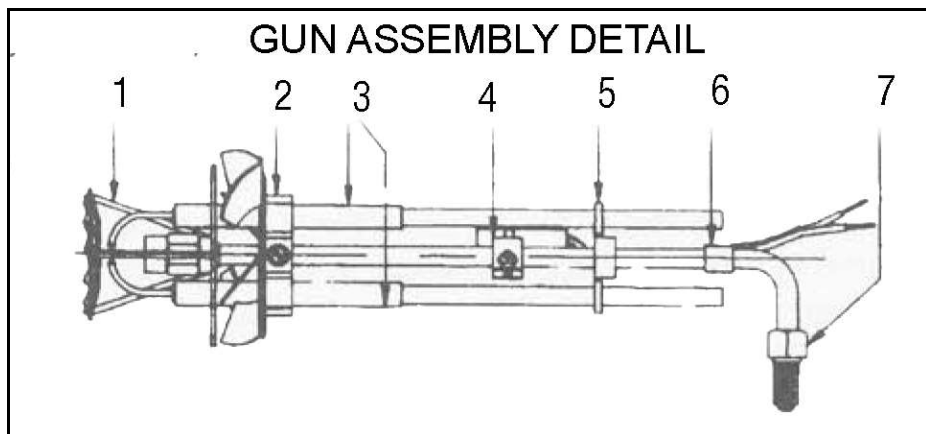
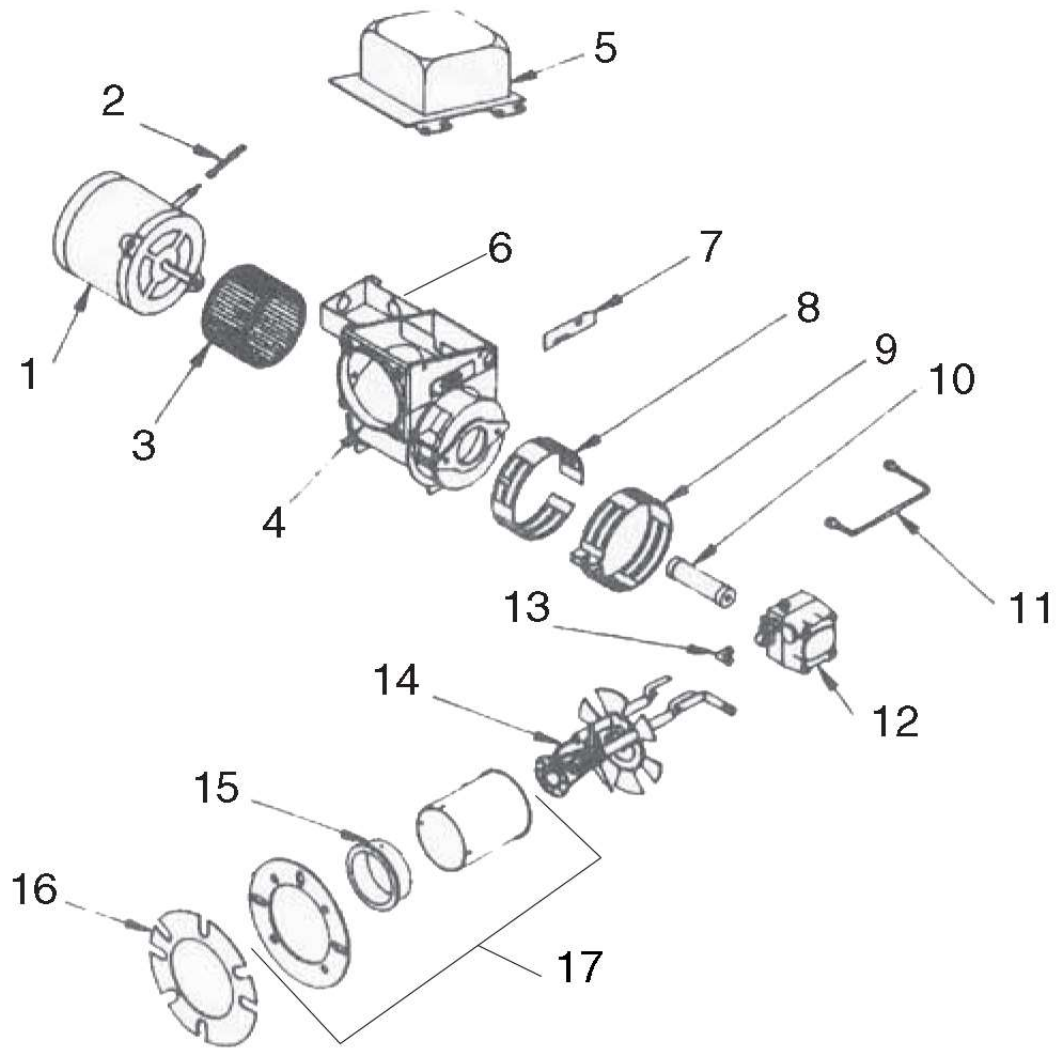

**PHW-Series Wayne Burner**

REF	PART NO.	QTY	DESCRIPTION	NOTES
1	8.756-293.0	1	MOTOR, BURNER, 1/5 120V 50-60HZ	EHASR 4
-	8.756-436.0	1	MOTOR, 1/4 120V 50-60HZ	EHASR 5
2	13121	1	MOTOR CORD COVER	
3	8.700-730.0	1	BLOWER WHEEL, 5-.25' x 3-7/16(307000)	EHASR 4
-	8.756-438.0	1	FAN - 4.00"W X 6.25"D 1/2" BORE	EHASR 5
4	8.700-735.0	1	BURNER HOUSING EHASR	
5	8.700-802.0	1	IGNITOR, 120V, SIDE/EH-EHA MOUNT	
6	8.756-296.0	1	JUNCTION BOX, EHASR	
7	13392	1	SLOT COVER PLATE	
8	8.700-732.0	1	BAND, AIR BURNER INNER EHA/SR	
9	8.700-729.0	1	AIR BAND 8 HOLE OUTER EHA/SR	
10	13279	1	COUPLING A/B PUMP	
11	8.700-704.0	1	OIL LINE, 6'	
12	8.756-290.0	1	FUEL PUMP, WCS - COMBO/W SOLENOID 120V	
13	13494	1	BRASS 90° ELBOW	
14	8.756-450.0	1	GUN ASSEMBLY, BURNER-RG/*CST/GBB1	EHASR 4
-	8.756-704.0	1	ASSY, BURNER GUN, RG/SST/2"BB	EHASR 5
15	8.756-302.0	1	AIR CONE #8A	EHASR 4
-	8.700-724.0	1	CONE 4A FOR/307000,003,007	EHASR 5
16	8.700-692.0	2	GASKET, E & M SERIES BURNERS	
17	8.756-678.0	1	AIR TUBE AND WELDED FLANGE	

GUN ASSEMBLY DETAIL				
REF	PART NO.	QTY	DESCRIPTION	NOTES
1	12988-002	1	NOZZLE ADAPTER	
2	21923-001	1	ELECTRODE SUPPORT KIT	
3	13286	1	STEM/INSULATOR KIT	
4	13078	1	CAD CELL MOUNT	
5	13276-002	1	BUSS BAR SUPPORT	
6	100850-001	1	CAD CELL WIRE TIE	
7	14295	1	OIL PIPE FITTING	





