

# VHP Series

Hot Water - Electric Powered - LP Gas Heated

## Operator's Manual

USE VAPOR FUEL ONLY

Pressure Washer

MODELS:

VHP2-1500  
1.109-556.0

VHP3-2000  
1.109-557.0

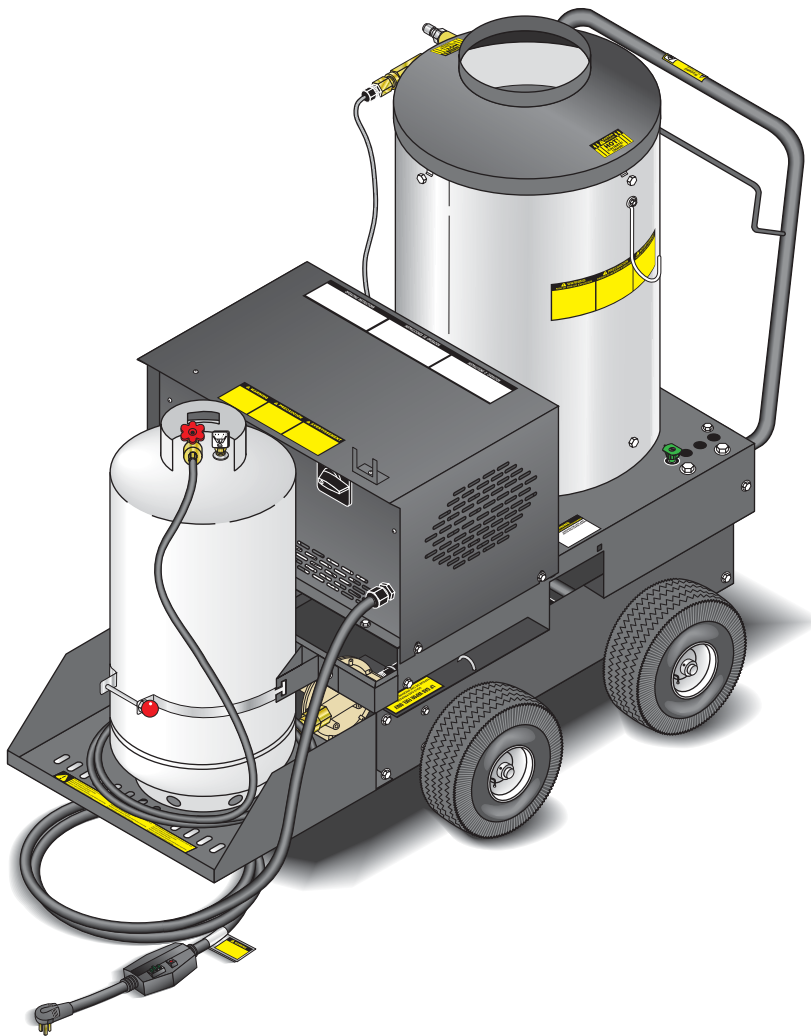

For the dealer nearest you,  
consult our web page at  
[www.kaercher/us.com](http://www.kaercher/us.com)



Intertek

8.913-949.0-AF



01/06/20

**Machine Data Label**

---

Model: \_\_\_\_\_

Date of Purchase: \_\_\_\_\_

Serial Number: \_\_\_\_\_

Dealer: \_\_\_\_\_

Address: \_\_\_\_\_

Phone Number: \_\_\_\_\_

Sales Representative: \_\_\_\_\_

**Machine Data Label . . . . .2**  
**Table of Contents . . . . .3**  
**How To Use This Manual . . . . .4**

**Safety**

Introduction & Safety Information . . . . .5  
Important Safety Information. . . . .6  
Propane Tank Safety Instructions. . . . .9

**Operations**

Installation. . . . .11  
Check Water Heater Coil For Leaks . . . . .13  
Instructions for lighting . . . . .13  
Assembly Instructions. . . . .14  
Operating Instructions. . . . .15  
Detergents & General Cleaning Techniques . . . . .17

**Maintenance**

Shutting Down And  
Clean-up . . . . .18  
Storage . . . . .19  
After Extended Storage. . . . .19  
Engine Maintenance . . . . .19  
Preventative Maintenance . . . . .19  
Maintenance And Service. . . . .20  
Unloader Valves . . . . .20  
Winterizing Procedure. . . . .20  
High Limit Hot Water Thermostat . . . . .20  
Pumps. . . . .20  
Cleaning of Coils. . . . .20  
Removal of Soot and Heating Coil . . . . .20  
Pressure Relief Valve . . . . .21  
Rupture Disk . . . . .21  
Propane Cylinder Capacity . . . . .21  
Oil Change Record . . . . .22  
Troubleshooting . . . . .23

**Parts**

VHP Left . . . . .26  
VHP Right. . . . .27  
Hose & Spray Gun . . . . .32  
Injector Assembly #2 - 4 - 011182 . . . . .34  
GB Series Pump. . . . .36  
VRT3 Unloader . . . . .38

**Spanish**

Seguridad De La Maquina . . . . .40  
Instalacion. . . . .42  
Instrucciones De Operacion . . . . .44  
Mantenimiento Y Servicio. . . . .45

## How To Use This Manual

This manual contains the following sections:

- How to Use This Manual
- Safety
- Operations
- Maintenance
- Parts List
- Spanish

The HOW TO USE THIS MANUAL section will tell you how to find important information for ordering correct repair parts.

Parts may be ordered from authorized dealers. When placing an order for parts, the machine model and machine serial number are important. Refer to the MACHINE DATA box which is filled out during the installation of your machine. The MACHINE DATA box is located on the inside of the front cover of this manual.

Model: _____
Date of Purchase: _____
Serial Number: _____
Dealer: _____
Address: _____
Phone Number: _____
Sales Representative: _____

The model and serial number will be found on a decal attached to the pressure washer.

The SAFETY section contains important information regarding hazardous or unsafe practices of the machine. Levels of hazards are identified that could result in product damage, personal injury, or severe injury resulting in death.

The OPERATIONS section is to familiarize the operator with the operation and function of the machine.

The MAINTENANCE section contains preventive maintenance to keep the machine and its components in good working condition. They are listed in this general order:

- Storage
- After Extended Storage
- Engine Maintenance
- Preventative Maintenance
- Unloader Valves
- Winterizing Procedure
- High Limit Hot Water Thermostat
- Pumps
- Cleaning of Coils
- Removal of Soot and Heating Coil
- Rupture Disk
- Propane Cylinder Capacity
- Oil Change Record
- Troubleshooting

The PARTS LIST section contains assembled parts illustrations and corresponding parts list. The parts lists include a number of columns of information:

- **REF** – column refers to the reference number on the parts illustration.
- **PART NO.** – column lists the part number for the part.
- **QTY** – column lists the quantity of the part used in that area of the machine.
- **DESCRIPTION** – column is a brief description of the part.
- **NOTES** – column for information not noted by the other columns.

*NOTE: If a service or option kit is installed on your machine, be sure to keep the KIT INSTRUCTIONS which came with the kit. It contains replacement parts numbers needed for ordering future parts.*

*NOTE: The manual part number is located on the lower right corner of the front cover.*

## **Introduction & Safety Information**

Thank you for purchasing this Pressure Washer. We reserve the right to make changes at any time without incurring any obligation.

### **Owner/User Responsibility:**

The owner and/or user must have an understanding of the manufacturer's operating instructions and warnings before using this pressure washer. Warning information should be emphasized and understood. If the operator is not fluent in English, the manufacturer's instructions and warnings shall be read to and discussed with the operator in the operator's native language by the purchaser/owner, making sure that the operator comprehends its contents.

Owner and/or user must study and maintain for future reference the manufacturers' instructions.

The operator must know how to stop the machine quickly and understand the operation of all controls. Never permit anyone to operate the engine without proper instructions.

### **SAVE THESE INSTRUCTIONS**

**This manual should be considered a permanent part of the machine and should remain with it if machine is resold.**

**When ordering parts, please specify model and serial number. Use only identical replacement parts.**

**This machine is to be used only by trained operators.**

## Important Safety Information



**WARNING:** To reduce the risk of injury, read operating instructions carefully before using.

**AVERTISSEMENT:** Pour réduire le risque de blessures, lire attentivement les instructions de fonctionnement avant l'utilisation

1. Read the owner's manual thoroughly. Failure to follow instructions could cause malfunction of the machine and result in death, serious bodily injury and/or property damage.
2. Know how to stop the machine and bleed pressure quickly. Be thoroughly familiar with the controls.
3. Stay alert — watch what you are doing.
4. Do not replace LP tank while machine is running.
5. All installations must comply with local codes. Contact your electrician, plumber, utility company or the selling dealer for specific details. If your machine is rated 250 volts or less, single phase a ground fault circuit interrupter (GFCI) will be provided. If rated more than 250 volts, or more than single phase this product should only be connected to a power supply protected by a GFCI.

**WARNING:** Must be plugged into properly wired three hole grounded outlet that accommodates plug on power cord. Failure to comply could result in electrical shock.

**AVERTISSEMENT:** Doit être raccordé dans une sortie à trois trous mise à la masse et correctement câblée qui peut accueillir une fiche sur un cordon d'alimentation. Le non-respect de cette consigne pourrait causer un choc électrique.

**DANGER:** Improper connection of the equipment-grounding conductor can result in a risk of electrocution. Check with a qualified electrician or service personnel if you are in doubt as to whether the outlet is properly grounded. Do not modify the plug provided with the product - if it will not fit the outlet, have a proper outlet installed by a qualified electrician. Do not use any type of adaptor with this product.

**DANGER:** Une mauvaise connexion du conducteur de terre de l'équipement peut entraîner un risque d'électrocution. Vérifier auprès d'un électricien qualifié ou du personnel d'entretien si vous avez

des doutes quant à savoir si la sortie est correctement mise à la masse. NE PAS modifier la fiche fournie avec le produit - si elle n'entre pas dans la sortie, faire installer une sortie appropriée par un électricien qualifié. NE JAMAIS utiliser un adaptateur avec ce produit.



**WARNING:** Keep wand, hose, and water spray away from electric wiring or fatal electric shock may result.

**AVERTISSEMENT:** Garder la lance, le boyau et le jet d'eau à l'écart de tout câblage électrique ou des chocs électriques mortels pourraient survenir

6. To protect the operator from electrical shock, the machine must be electrically grounded. It is the responsibility of the owner to connect this machine to a UL grounded receptacle of proper voltage and amperage ratings. Do not spray water on or near electrical components. Do not touch machine with wet hands or while standing in water. Always disconnect power before servicing.

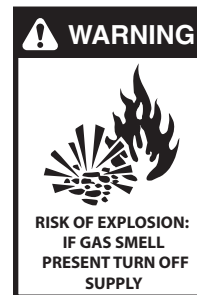

**WARNING:** Flammable liquids can create fumes which can ignite, causing property damage or severe injury.

**AVERTISSEMENT:** Des liquides inflammables peuvent produire des vapeurs qui peuvent s'enflammer, causant ainsi des dommages à la propriété ou des blessures graves.

**WARNING:** Risk of explosion — Operate only where open flame or torch is permitted.

**AVERTISSEMENT:** Risque d'explosion- Utiliser uniquement dans des endroits où l'utilisation d'une flamme nue ou d'une torche est permise.



**WARNING:** Risk of fire — Do not change tanks when the product is operating or still hot.

**AVERTISSEMENT:** Risque d'incendie - Ne pas changer les réservoirs pendant que le produit est en marche ou encore chaud.

**WARNING:** Use vapor fuel only.

**AVERTISSEMENT: Utiliser des vapeurs de carburant seulement.**

- Oil burning appliances shall be installed only in locations where combustible dusts and flammable gases or vapors are not present. Do not store or use gasoline near this machine.
- Keep operating area clear of all persons.



**WARNING: High pressure spray can cause paint chips or other particles to become airborne and fly at high speeds. To avoid personal injury, eye, hand and foot safety devices must be worn.**

**AVERTISSEMENT: Un jet haute pression peut écailler la peinture ou provoquer l'émission d'autres particules dans l'air et leur**

**projection à hautes vitesses. Pour éviter les lésions corporelles, une protection des yeux, du visage, des mains et des pieds doit être portée lors de l'utilisation de cet équipement.**

- Always wear properly rated eye protection such as safety goggles or face shield while spraying. (Safety glasses do not provide full protection.)



**WARNING: This machine exceeds 85 db appropriate ear protection must be worn.**

**AVERTISSEMENT: Cette machine excède 85 dB et une protection de l'ouïe appropriée doit être portée.**



**CAUTION: Hot discharge fluid. Do not touch or direct discharge stream at persons or animals.**

**ATTENTION: Liquide de décharge chaud. Ne pas toucher ou décharger directement le jet vers des personnes ou des animaux,**

**WARNING: This machine produces hot water and must have insulated components attached to protect the operator.**

**AVERTISSEMENT: Cette machine produit de l'eau chaude et doit comporter des composants isolés attachés pour protéger l'opérateur.**



**WARNING: Risk of injury. Hot surfaces can cause burns. Use only designated gripping areas of spray gun and wand. Do not place hands or feet on non-insulated areas of the pressure washer.**

**AVERTISSEMENT: Risque de blessures. Les surfaces chaudes peuvent causer des brûlures.**

**Utiliser uniquement les zones de prise désignées du pistolet pulvérisateur et de la lance. Ne pas placer les mains ou les pieds sur des endroits non isolés de la laveuse à pression.**

- To reduce the risk of injury, close supervision is necessary when a machine is used near children. Do not allow children to operate the pressure washer. **This machine must be attended during operation.**



**WARNING: Grip cleaning wand securely with both hands before starting. Failure to do this could result in injury from a whipping wand.**

**AVERTISSEMENT: Agripper la lance de nettoyage avec les deux mains avant de commencer. Le non-respect de cette consigne**

**pourrait mener à des blessures causées par le mouvement violent de la lance.**

- Never make adjustments on machine while in operation.
- Be certain all quick coupler fittings are secured before using pressure washer.



**WARNING: High pressure developed by these machines will cause personal injury or equipment damage. Keep clear of nozzle. Use caution when operating. Do not direct discharge stream at people and animals, or severe injury or death will result.**

**AVERTISSEMENT: La haute pression générée par ces machines causera des lésions corporelles ou des dommages à l'équipement. Se tenir à l'écart de la buse. Faire preuve de prudence lors de l'utilisation. Ne pas décharger directement le jet vers des personnes ou des animaux, car cela risquerait de causer des blessures graves ou même la mort.**



**WARNING: Protect machine from freezing.**

**AVERTISSEMENT: Protéger la machine contre le gel.**

13. To keep machine in best operating conditions, it is important you protect machine from freezing. Failure to protect machine from freezing could

cause malfunction of the machine and result in death, serious bodily injury, and/or property damage. Follow storage instructions specified in this manual.

14. Inlet water must be clean fresh water and no hotter than 90°F.



**DANGER: Risk of asphyxiation. Use this product only in a well ventilated area.**

**DANGER: Risque d'asphyxie. Ne pas inhaler les vapeurs.**

15. Running this product indoors can result in death due to carbon monoxide, a poison gas you cannot see or smell. Only

use outdoors and far away from windows, doors and openings or vents.

16. Manufacturer will not be liable for any changes made to our standard machines or any components not purchased from us.

17. The best insurance against an accident is precaution and knowledge of the machine.



**WARNING: Be extremely careful when using a ladder, scaffolding or any other relatively unstable location. The cleaning area should have adequate slopes and drainage to reduce the possibility of a fall due to slippery surfaces.**

**AVERTISSEMENT: Faire preuve d'une extrême prudence au moment d'utiliser une échelle, des échafaudages ou toute autre surface relativement instable. La zone de nettoyage doit avoir une pente et un drainage adéquats pour réduire la possibilité d'une chute due à une surface glissante.**

18. Do not overreach or stand on unstable support. Keep good footing and balance at all times.

19. Do not operate this machine when fatigued or under the influence of alcohol, prescription medications, or drugs.

20. Follow the maintenance instructions specified in the manual.

21. Do not replace LP tank while machine is running. Serious injury could result.

**WARNING: Use vapor fuel only.**

**AVERTISSEMENT: Utiliser des vapeurs de carburant seulement.**

22. The LP models are designed to run on vapor propane fuel. Do not use liquid fuel. Have a qualified serviceman install and service your equipment.

23. Never expose a spark or flame where there may be unburned gas present.

24. Install the machine 18" above the floor and about 2 feet from wall providing adequate ventilation and space.

25. When making repairs disconnect from electrical source and shut off gas valve.

26. Install this machine on non combustible flooring.

27. Do not allow acids, caustic or abrasive fluids to pass through the pump.

28. Never run pump dry or leave spray gun closed longer than 1-2 minutes.



**WARNING: If connection is made to potable water supply, a back flow device must be provided.**

**Si une connexion est établie avec un approvisionnement en eau potable, un dispositif de protection contre le retour d'eau doit être fourni.**



**WARNING: Do not spray machine or any people, animals or electrical parts.**

**AVERTISSEMENT: Ne pas vaporiser sur la machine ou les gens, les animaux ou les pièces électriques.**



Follow the maintenance instructions specified in the manual.

**Suivre les instructions d'entretien spécifiées dans le manuel.**



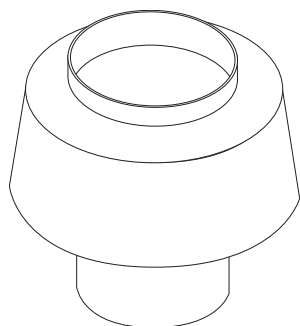

**Example Of Down  
Draft Diverter For Gas Fired Machines**

## Propane Tank Safety Instructions

**CAUTION:** Only qualified persons should fill your LP-Gas containers.

**ATTENTION:** Les contenants de gaz de pétrole liquéfié doivent être remplis uniquement par des personnes qualifiées.

1. Never allow your LP-gas container to be filled above the maximum safe level as indicated by a scale or the fixed liquid level gauge (ou tage). Do not use the visible gauge for filling.
2. Do not use a wrench or pliers to close the service valve or fixed liquid level gauge. These valves are designed to be closed leak-tight by hand or screwdriver as appropriate. If wrenches are necessary to stop a leak, the valve needs repair or replacement.
3. When tightening the POL Nut (left hand thread) on the service valve, draw it up snug with a proper wrench. This is a machined male brass fitting which seats securely against a female seat in the POL valve – no pipe dope is necessary. Acme/Type 1 valves have right handed threads which are secure when hand tight, and on the Quick Disconnect/Type 2 Valves, the male connection is inserted into the female connection on the cylinder valve. (No wrenches required for both the Acme and the Quick Disconnect.)
4. When using container, slowly open service valve all the way. Listen to the regulator. A continuous hiss may indicate a leak or an open valve on an appliance.
5. Check all tank and the line connections periodically to be sure they are tight. When testing for leaks, use approved leak detector solution – not matches.
6. Make certain your container is properly fastened in place.
7. Turn container with open part of container guard towards frame. This protects valves and regulator against flying rocks and mud. Transport container in the proper position in which it is used, with the valves closed and POL Plugs inserted for POL Valves or Dust Caps for Acme Valves. Secure the tank against falling or rolling.
8. Check for leaks after connecting. Apply approved leak detector solution to connection, turn off all burners and pilots, and open service valve. Leaks will be detected by the growth of the bubbles. If bubbles grow, tighten or repair the connection as needed. Repeat leak test until problem is corrected.
9. LP-gas is normally non-corrosive – you need not worry about the inside of your container. However, the outside should be kept free from rust by a periodic coat of paint in a light reflective color. It is very important to inspect and maintain the bottom and foot ring on the container.
10. Do not store LP-gas containers indoors or in enclosed areas. Do not expose LP-gas container to heat. Always store with service valve closed and plugged as required.
11. Do not attempt to repair any containers, container valves, regulator or appliances by yourself. Use only trained certified LP-gas service personnel to perform repairs.

**CAUTION:** Propane tanks, gas bottles will not be picked up by local garbage collectors. Improper propane tank disposal might be illegal in some areas.

**ATTENTION:** Les bouteilles de propane, les bouteilles de gaz ne seront pas acceptées par les éboueurs locaux.

Propane tank disposal is a safety issue that is easily handled by a propane company.

# Operations

## Component Identification

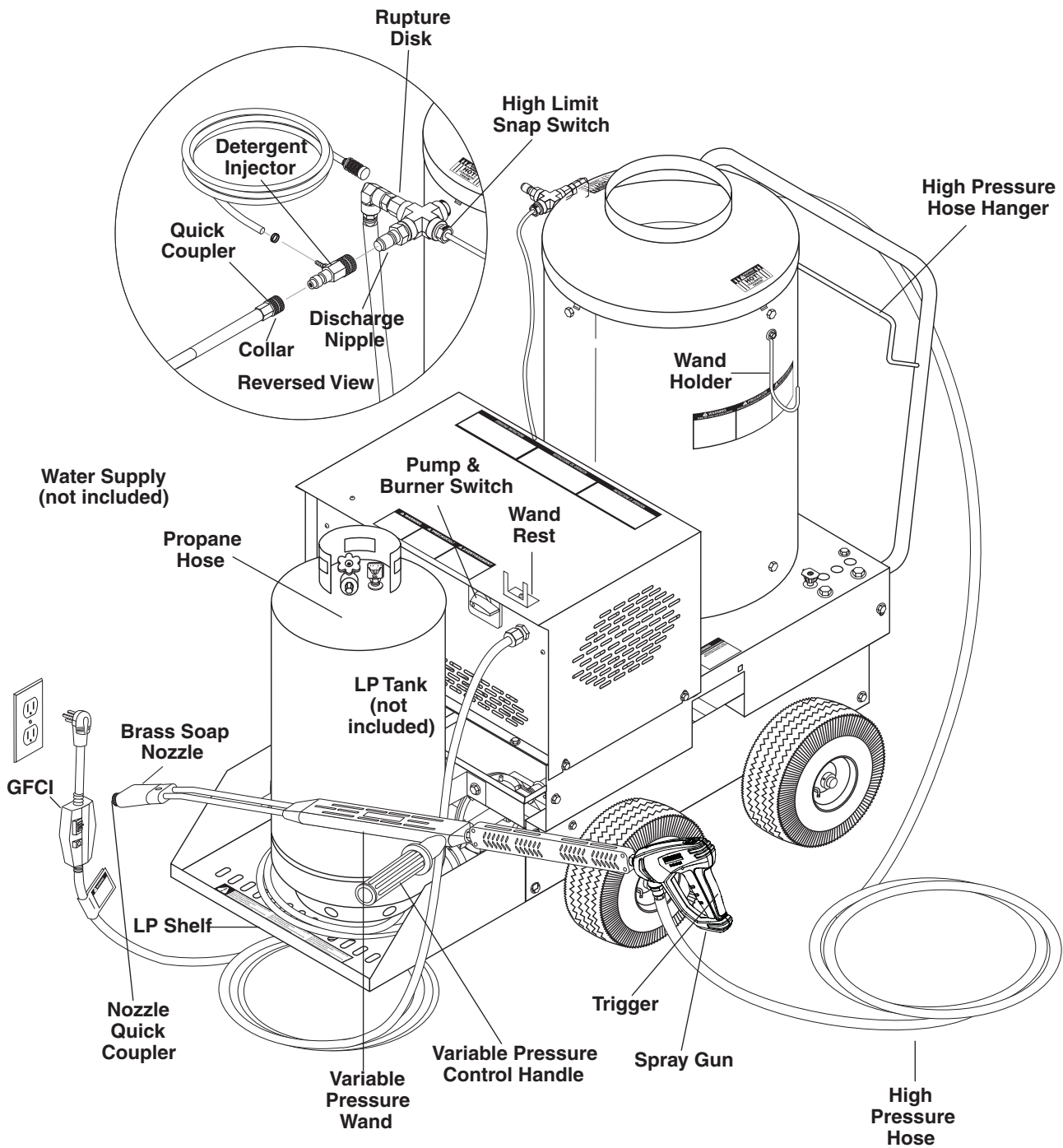

## Installation

**WARNING:** *Moving this machine on an incline may cause instability and could result in the machine tipping over. Equipment damage or bodily harm could occur.*

**AVERTISSEMENT:** *Le déplacement de cette machine sur une pente pourrait causer une instabilité et pourrait amener la machine à se renverser. Risque de dommage à l'équipement ou de lésions corporelles.*

Place machine in a convenient location providing ample support, drainage and room for maintenance.

**These machines are intended for indoor use.  
Machine must be stored indoors when not in use.**

## Location

The location should protect the machine from damaging environmental conditions, such as wind, rain and freezing.

1. The machine should be run on a level surface where it is not readily influenced by outside sources such as strong winds, freezing temperatures, rain, etc. Consider accessibility for the replacing of LP tanks, refilling of detergents, adjustments and maintenance when selecting a location. Normal precautions should be taken by the operator to prevent excess moisture from reaching electrical components.
2. It is recommended that a partition be made between the wash area and the machine to prevent direct spray from the spray gun to come in contact with machine. Excess moisture reaching the electrical controls will reduce the machine life and may cause electrical shorts.
3. During installation, beware of poorly ventilated locations or areas where exhaust fans may cause an insufficient supply of oxygen. Sufficient combustion can only be obtained when there is a sufficient supply of oxygen available for the amount of fuel being burned. If it is necessary to install in a poorly ventilated area, outside fresh air may have to be piped to the burner and a fan installed to bring air into the room. Avoid small locations or areas near exhaust fans.

## Gas Codes

Confer with local gas company and with proper municipal officials regarding any specific code or regulations governing the installation. The installation must conform to local codes.

The gas pressure coming out of the regulator and going to the burner ring has been factory set for elevations of 0 to 2000 ft. Altitudes greater than 2000 ft will require adjustments to the gas manifold pressures. Consult your local service dealer for high altitude adjustments. In Canada, certification for installation at altitudes over 4500 feet above sea level is the jurisdiction of local authorities. You should not readjust the burner ring gas pressure. If you replace your gas valve, you will need to adjust the new valve. Refer to your machine's specification plate for the correct pressure setting. Follow the installation and adjustment instructions provided with your replacement valve.

*NOTE: Air for combustion and ventilation along with exhaust flue sizing must conform to methods outlined in current American Standard (ANSI-Z223.1) National Fuel Gas Code or National Standard of Canada CSA-149.1 and CSA-149.2 "Installation Code for Gas Burning Appliances".*

## Electrical

This machine, when installed, must be electrically grounded in accordance to local codes. Check for proper power supply using a volt meter. The VHP2-15021D requires a 20 amp receptacle to comply with UL 1776 certification standards.

## Venting

Regulations or ventilation concerns may call for a chimney or furnace pipe. When venting, if the machine is to be in an enclosed area with a chimney on it, be sure the chimney is the same size as the stack on the machine. Poor draft will cause machine to soot and not operate efficiently. When placing for installation, keep in mind that the pressure washer should be positioned in such a manner that the stack will be as straight as possible and protrude through the roof of the building at a proper location and at sufficient height to eliminate downdraft. The chimney of gas fired machines should be installed with a down draft diverter.

## Operations

### Draft Diverter

A draft diverter should be installed above the heating coil. The diverter serves to sever the chimney effect created in all sections of furnace pipe positioned below to enhance the draft through the burner. It also helps prevent freezing of the coil due to wind chill factors.

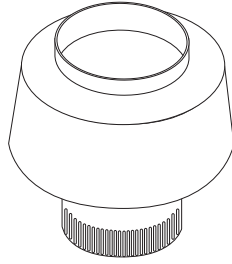

*NOTE: The draft diverter is not standard on VHP machines.*

When the pressure washer is installed in a tightly closed room without ventilation openings to the outdoors or other rooms, provisions shall be made for supplying air for combustion through special openings, one near the floor line and the other near the ceiling, each to be sized on the basis of one square inch or more of free area for each 1,000 BTU input per hour.

### Placement

Do not locate near any combustible material. Keep all flammable material at least 20 feet away.

Allow enough space for servicing the machine.

Local code will require certain distances from floor and walls. (Two feet away should be adequate.)

### Water Source

Water source for machine should be supplied by a 5/8" I.D. garden hose with a city water pressure of not less than 30 psi. If the water supply is inadequate, or if the garden hose is kinked, the machine will run very rough and the burner will not fire.

### Connection

Connect the wand, nozzle, hose and spray gun (where applicable). On pipe thread connections, use teflon tape to avoid water leaks. (See Component Identification.)

Attach high pressure hose to discharge nipple by pulling the quick coupler collar back and inserting it onto the discharge nipple. Then push the collar forward to secure. A detergent injector could be inserted between the hose coupler and the discharge nipple. (Assembly Instructions)

Place detergent dip tube into liquid soap or detergent solution. Avoid letting tube suck air.

**CAUTION:** *When installing propane hose to LP tank, please note that it has left hand threads.*

**ATTENTION:** *Au moment de l'installation du tuyau de propane au réservoir de pétrole liquide, veuillez prendre note que ce dernier est muni de raccords sur la gauche et la droite*

### Inspection and Testing

Before turning gas under pressure into piping, all openings from which gas can escape should be closed. Immediately after turning on gas, the system should be checked for leaks. This can be done by watching the 1/2 cubic foot test dial and allowing 5 minutes to show any movement, or by soaping each pipe connection and watching for bubbles. If a leak is found, make the necessary repairs and repeat the above test.

Defective pipes or fittings should be replaced and not repaired. Never use a flame or fire in any form to locate gas leaks, use a soap solution.

After the piping and meter have been checked completely, purge the system of air. **DO NOT** bleed the air inside an enclosed room.

The pressure washer and its individual shut-off valve must be disconnected from the gas supply piping system during the pressure testing of that system at test pressure in excess of 1/2 psig or damage to the gas valve will occur.

### Shut-Off Valve

A gas shut-off valve has been installed between the gas supply line and the washer. The plumbing also includes a union between the shut-off valve and the burner.

### Condensation from Coils

When cold water is being pumped into the water heater coils, and the burners are on, condensation will form on the coils and drip down into the burner compartment giving the appearance of a leaking coil, particularly on cold humid days.

### Check Water Heater Coil For Leaks

With the burner "OFF" start the pumping machine and allow to run for a few minutes. Look into the burner compartment with a drop light or flashlight. If no leak is visible, then subsequent water dripping from the coil will be from condensation in the flue gases when the burner is on, as described in the previous paragraph.

PRE-START CHECK LIST	YES	NO
Is machine protected from downdraft and excessive wind?		
Is machine shielded from moisture or water spray?		
Is the voltage correct and circuit breaker and supply cord adequate according to specifications and serial plate notation?		
Is the machine electrically grounded?		
Is there ample water supply?		
Have all flammable liquids or gases been removed from installation location?		
Is the machine properly vented to allow adequate air flow?		
Is there an adequate gas supply for the BTU rating of the burner?		
Have gas lines been checked for gas leaks?		
Have all operators using this machine been instructed properly & have they read the manual?		
Has the machine been installed according to the instructions in the operator's manual?		
Is the incoming gas supply pressure to the machine between 6-14 water column inches or 1/2 psig?		

### Instructions for lighting



**WARNING:** If "NO" has been checked on any of the above questions, do not operate.

**AVERTISSEMENT:** Si la réponse à l'une des questions ci-dessus est « NON », ne pas utiliser la machine.

**WARNING:** If you do not follow instructions exactly, a fire or explosion may result causing property damage, personal injury or loss of life.

**AVERTISSEMENT:** Si ces directives ne sont pas suivies à la lettre, un incendie ou une explosion pourrait survenir et entraîner des dommages à la propriété, des lésions corporelles ou la mort.

1. This machine has a pilot which must be lighted by hand. When lighting the pilot, follow these instructions exactly.
2. **BEFORE LIGHTING** smell all around the appliance area for gas. Be sure to smell next to the floor because propane gas is heavier than air and will settle on the floor.

### For your safety:

### WHAT TO DO IF YOU SMELL GAS

- a. Do not try to light any appliance.
  - b. Do not touch any electrical switch; do not use any phone in your building.
  - c. Immediately call your gas supplier from a neighbor's phone. Follow the gas supplier's instructions.
  - d. If you cannot reach your gas supplier, call the fire department.
3. Use only your hand to push in or turn gas control knob. Never use tools. If the knob will not push in or turn by hand, don't try to repair it, call a qualified service technician. Force or attempted repair may result in a fire or explosion.
  4. Do not use this machine if any part has been under water. Immediately call a qualified service technician to inspect the machine and to replace any part of the control system or any gas control that has been under water.

# Operations

## Assembly Instructions

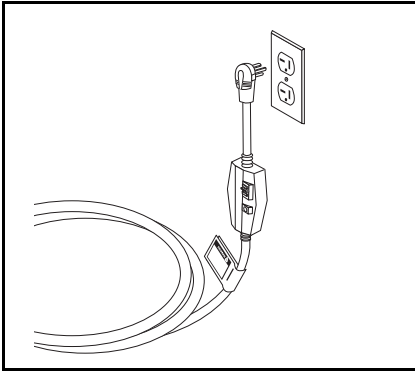

**STEP 1:** Connect power cord to proper electrical outlet according to serial plate information. Push in GFCI reset button. The VHP2-15021D requires a 20 amp receptacle.

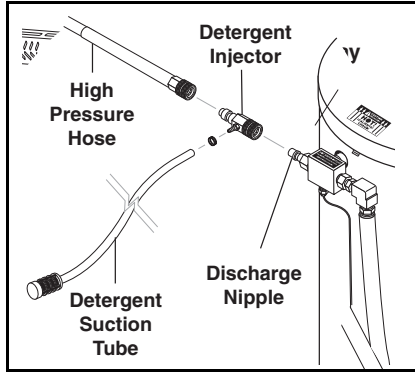

**STEP 2:** Connect high pressure hose to discharge nipple by sliding quick coupler collar back. (If detergent is to be applied, insert a detergent injector.) Insert quick coupler onto discharge nipple and secure by pushing quick coupler collar forward.

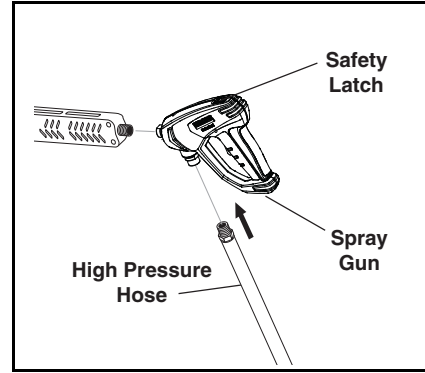

**STEP 3:** Attach the high pressure hose to the spray gun using teflon tape on hose threads. Move safety latch into locked position.

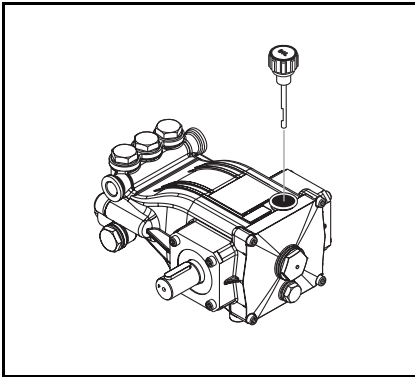

**STEP 4:** Check oil level by using supplied dip-stick. Use SAE 10W-40 non-detergent only.

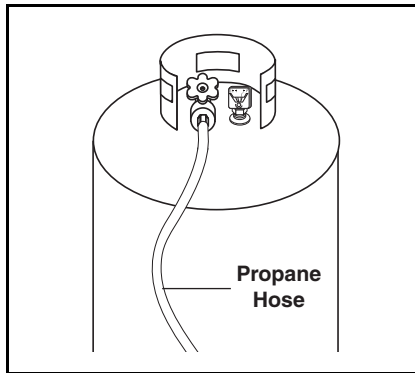

**STEP 5:** Connect propane hose to a propane tank.

**Operating Instructions**

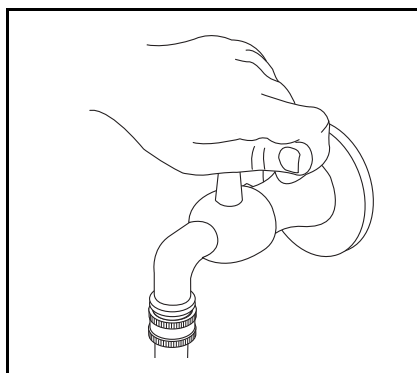

**STEP 1: STOP!** Read operator's manual before operating this machine. Failure to read operation and warning instructions may result in personal injury or property damage. Connect water supply hose to inlet connector and turn water on.

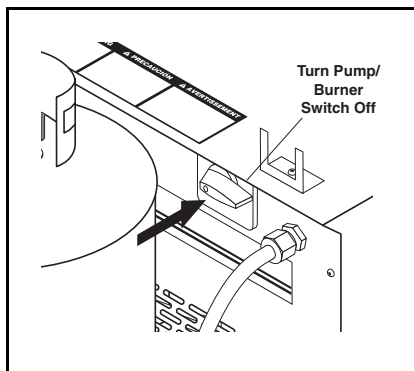

**STEP 2:** Turn all switches off. Remove and position LP tank as far from machine as supply hose will allow.

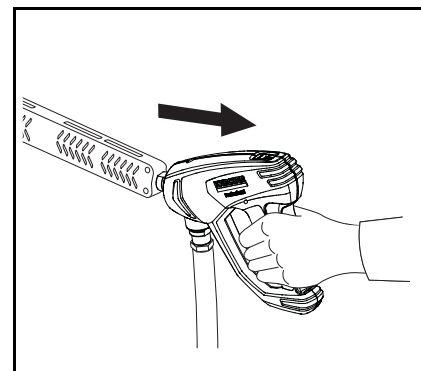

**STEP 3:** Before installing nozzle, Pull trigger on spray gun allowing water to flow until all air has been discharged from the system. Check for water leaks and tighten as needed.

Grip spray gun variable pressure wand securely. Then turn the variable pressure control handle counterclockwise to flush any debris out of soap nozzle.

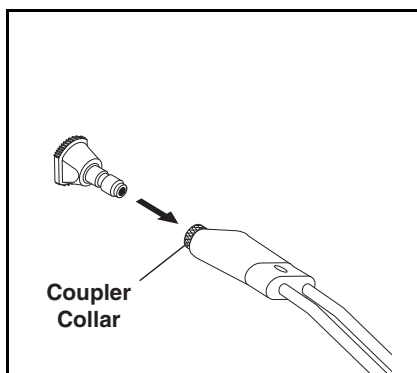

**STEP 4:** Pull the spring-loaded collar of the wand coupler collar back to insert your choice of pressure nozzle. **CAUTION: Never replace nozzles without engaging the safety latch on the spray gun trigger.**

**ATTENTION: Ne jamais remplacer les buses sans d'abord mettre le dispositif de sécurité sur la détente du pistolet pulvérisateur.**

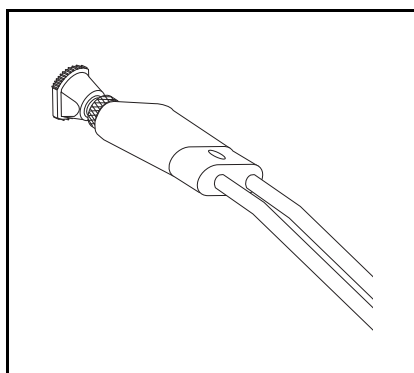

**STEP 5:** Release the coupler collar and push the nozzle until the collar clicks. Pull the nozzle to make sure it is seated properly.

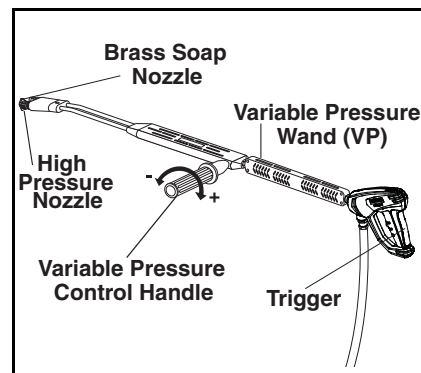

**STEP 6:** Selection of high or low pressure is accompanied by turning the handle.

**NOTE:** High pressure nozzle must be inserted at end of wand to obtain high pressure. To apply soap read operator's manual.

## Operations

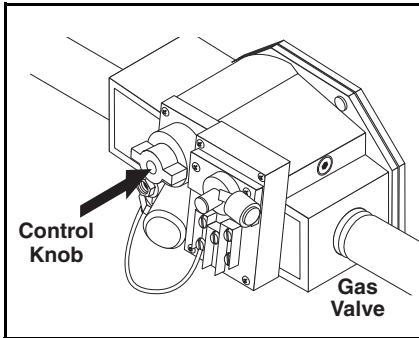

**STEP 7:** Open valve on LP tank, then slightly depress main gas valve control knob on the right side of the machine and turn it counterclockwise to the Pilot position.

*NOTE: Knob cannot be turned from "Pilot" to "OFF" unless the knob is slightly depressed.*

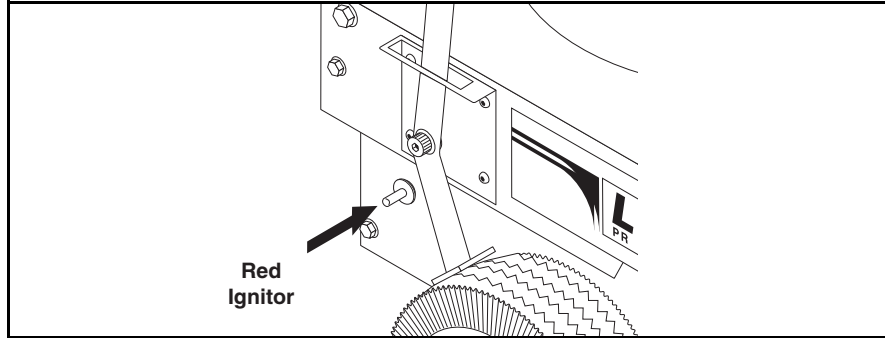

**STEP 8:** Depress the control knob all the way and hold it in. After five (5) seconds, depress the red ignitor until you hear a loud click. Repeat 3 or 4 times if necessary until pilot is lit. If pilot does not remain lit, repeat operation allowing a longer period of time before releasing the gas valve knob. After the pilot lights, continue to hold the control knob down for about one (1) minute before releasing. Look at the pilot viewing mirror at the rear of the machine.

Turn gas control knob counterclockwise to "ON."

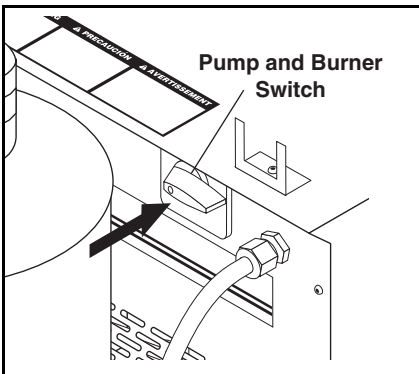

**STEP 9:** Turn switch to pump position and pull the trigger on the spray gun. Turn variable pressure control wand handle clockwise to obtain pressure for cold water operation.

For hot water, turn the switch to the burner position and pull the trigger on the spray gun. To apply detergent, read section on Detergents and General Cleaning Techniques



## Detergents & General Cleaning Techniques

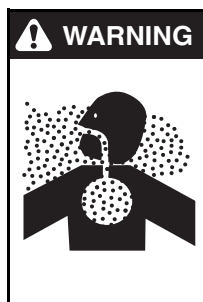

**WARNING:** Some detergents may be harmful if inhaled or ingested, causing severe nausea, fainting or poisoning. The harmful elements may cause property damage or severe injury.

**AVERTISSEMENT:** Certains détergents peuvent être dangereux s'ils sont inhalés ou

ingérés, provoquant de fortes nausées, des évanouissements et l'empoisonnement. Les éléments dangereux peuvent causer des dommages à la propriété ou des blessures graves.

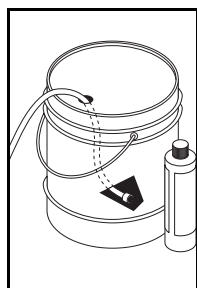

**STEP 1:** Use detergent designed specifically for pressure washers. Household detergents could damage the pump. Prepare detergent solution as required by the manufacturer. Fill a container with pressure washer detergent. Place the filter end of detergent suction tube into the detergent container.

**STEP 2:** Apply safety latch to spray gun trigger.

**NOTE:** Detergent cannot be applied using the yellow nozzle.

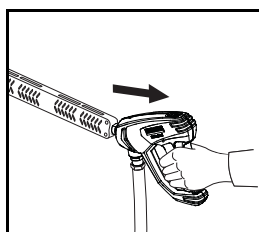

**STEP 3:** With the motor running, pull trigger to operate machine. Liquid detergent is drawn into the machine and mixed with water at an approximate ratio of 15 to 1. Turn pressure control handle on wand counterclockwise. This

lowers the pressure by directing the water flow through the soap nozzle and allow detergent injector to siphon soap.

Apply detergent to work area. Do not allow detergent to dry on surface.

**IMPORTANT:** You must flush the detergent injection system after each use by placing the suction tube into a bucket of clean water, then run the pressure washer in low pressure for 1-2 minutes.

## Cleaning Tips

Pre-rinse cleaning surface with fresh water. Place detergent suction tube directly into cleaning solution and apply to surface at low pressure (for best results, limit your work area to sections approximately 6 feet square and always apply detergent from bottom to top). Allow detergent to remain on surface 1-3 minutes. Do not allow detergent to dry on surface. If surface appears to be drying, simply wet down surface with fresh water. If needed, use brush to remove stubborn dirt. Rinse at high pressure from top to bottom in an even sweeping motion keeping the spray nozzle approximately 1 foot from cleaning surface. Use overlapping strokes as you clean and rinse any surface. For best surface cleaning action, spray at a slight angle.

## Recommendations:

- Before cleaning any surface, an inconspicuous area should be cleaned to test spray pattern and distance for maximum cleaning results.
- If painted surfaces are peeling or chipping, use extreme caution as pressure washer may remove the loose paint from the surface.
- Keep the spray nozzle a safe distance from the surface you plan to clean. High pressure wash a small area, then check the surface for damage. If no damage is found, continue to pressure washing.



### CAUTION - Never use:

- Bleach, chlorine products and other corrosive chemicals
- Liquids containing solvents (i.e., paint thinner, gasoline, oils)
- Tri-sodium phosphate products
- Ammonia products or acid-based products

These chemicals will harm the machine and will damage the surface being cleaned.



### ATTENTION: Ne jamais utiliser :

- Eau de Javel, produits à base de chlore et autres produits chimiques corrosifs
- Liquides contenant des solvants (c.-à-d. diluant à peinture, essence, huiles, etc.)
- Produits à base de tripolyphosphate de sodium
- Ammoniac ou produits à base d'acide

## Maintenance

### Rinsing

It will take a few seconds for the detergent to clear. Apply safety latch to spray gun. Remove black soap nozzle from the quick coupler. Select and install the desired high pressure nozzle.

*NOTE: You can also stop detergent from flowing by simply removing detergent siphon tube from bottle.*

### Shutting Down And Clean-up

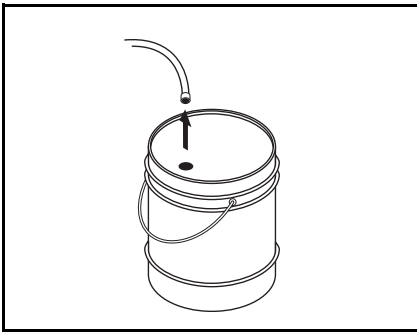

**STEP 1:** Remove detergent suction tube from container and insert into one (1) gallon of fresh water. Flush detergent lines with fresh water, switch to the pump position and continue to spray water allowing burner to cool.

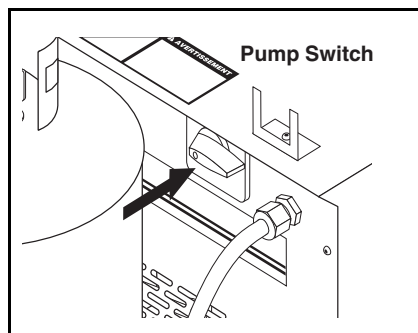

**STEP 2:** After water has cooled, turn pump off. Turn main gas valve off, then close the valve on the LP tank. Secure the LP tank to the machine when moving it.

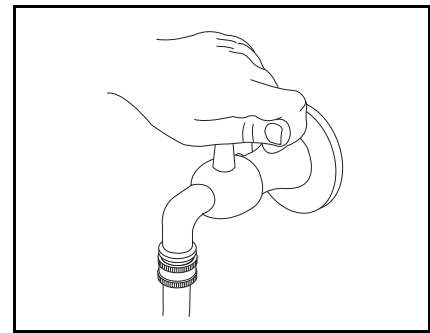

**STEP 3:** Turn the water off. To protect from freezing, pull the trigger on spray gun to allow water to drain from the system

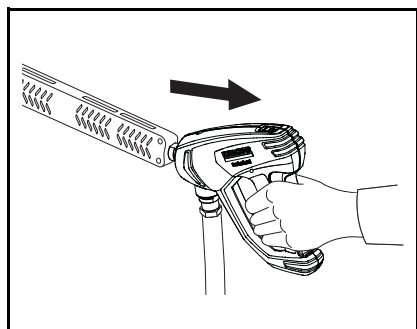

**STEP 4:** Squeeze trigger on spray gun to relieve remaining pressure. Move safety latch into its locked position.

## Storage

**CAUTION:** Always store your pressure washer in a location where the temperature will not fall below 32°F (0°C). The pump in this machine is susceptible to permanent damage if frozen. **FREEZE DAMAGE IS NOT COVERED BY WARRANTY.**

**ATTENTION:** Toujours entreposer la laveuse à pression dans un endroit où la température ne sera pas inférieure à 32°C (0 °F). La pompe sur cette machine est susceptible de subir des dommages si elle est exposée au gel. **LES DOMMAGES DUS AU GEL NE SONT PAS COUVERTS PAR LA GARANTIE.**

1. Stop the pressure washer, squeeze spray gun trigger to release pressure.
2. Detach water supply hose and high pressure hose.
3. Turn on the machine for a few seconds, until remaining water exits. Turn engine off immediately.
4. Drain the gas and oil from the engine.
5. Do not allow high pressure hose to become kinked.
6. Store the machine and accessories in a room which does not reach freezing temperatures.

**CAUTION:** Failure to follow the above directions will result in damage to your pressure washer.

**ATTENTION:** Le non-respect des directives ci-dessus entraînera des dommages à la laveuse à pression.

When the pressure washer is not being operated or is being stored for more than one month, follow these instructions:

1. Replenish engine oil to upper level.
2. Drain gasoline from fuel tank, fuel line, fuel valve and carburetor.
3. Pour about one teaspoon of engine oil through the spark plug hole, pull the starter grip several times and replace the plug. Then pull the starter grip slowly until you feel increased pressure which indicates the piston is on its compression stroke and leave it in that position. This closes both the intake and exhaust valves to prevent rusting of cylinder.
4. Cover the pressure washer and store in a clean, dry place that is well ventilated away from open flame or sparks. **NOTE:** The use of a fuel additive, such as STA-BIL<sup>®</sup>, or an equivalent, will minimize the formulation of fuel deposits during shortage. Such additives may be added to the gasoline in the fuel tank of the engine, or to the gasoline in a storage container.

## After Extended Storage



**CAUTION:** Prior to restarting, thaw out any possible ice from pressure washer hoses, spray gun or wand.

**ATTENTION:** Avant de redémarrer, faire fondre la glace se trouvant sur les boyaux, le pistolet pulvérisateur ou la lance de la laveuse à pression.

## Engine Maintenance

During the winter months, rare atmospheric conditions may develop which will cause an icing condition in the carburetor. If this develops, the engine may run rough, lose power and may stall. This temporary condition can be overcome by deflecting some of the hot air from the engine over the carburetor area.

**NOTE:** Refer to the engine manufacturer's manual for service and maintenance of the engine.

## Preventative Maintenance

1. Check to see that the water pump is properly lubricated.
2. Follow winterizing instructions to prevent freeze damage to the pump and coils.
3. Always neutralize and flush detergent from system after use.
4. If water is known to be high in mineral content, use a water softener in your water system or de-scale as needed.
5. Do not allow acidic, caustic or abrasive fluids to be pumped through system.
6. Always use high grade quality cleaning products.
7. Never run pump dry for extended periods of time.
8. Periodically de-lime coils as per instructions.

It is advisable, periodically, to visually inspect the burner. Check air inlet to make sure it is not clogged or blocked. Wipe off any oil spills and keep this equipment clean and dry.

The areas around the washer should be kept clean and free of combustible materials, gasoline and other flammable vapors and liquids.

The flow of combustion and ventilating air to the burner must not be blocked or obstructed in any manner.

### **Maintenance And Service**

#### **Unloader Valves**

Unloader valves relieve pressure in the line when the shut-off spray gun is closed. Unloader valves are preset and tested at the factory before shipping. Occasional adjustment of the unloader may be necessary to maintain correct pressure. (Contact your local dealer for correct procedure in adjusting unloader valve.)

Tampering with the factory setting may cause personal injury and/or property damage, and will void the manufacturer's warranty.

#### **Winterizing Procedure**

Damage due to freezing is not covered by warranty. Adhere to the following cold weather procedures whenever the washer must be stored or operated outdoors under freezing conditions.

During winter months, when temperatures drop below 32°F, protecting your machine against freezing is necessary. Store the machine in a heated room. If this is not possible then mix a 50/50 solution of anti-freeze/water into a 5 gallon bucket and with a short section of garden hose elevate the bucket and turn the pump on to siphon the anti-freeze through the machine. If compressed air is available, an air fitting can be screwed into the inlet connector and, by injecting compressed air, all water will be blown out of the system.

#### **High Limit Hot Water Thermostat**

For safety, each machine is equipped with a high limit control switch. In the event the temperature of the water should exceed its operating temperature, the high limit control will turn the burner off until the water cools.

#### **Pumps**

Use only SAE 10W-40 weight non-foaming oil. Change oil after first 50 hours of use. Thereafter, change oil every year or at 500 hour intervals. Oil level should be checked through use of the dipstick found on the top of the pump or by the red dot visible through the oil gauge window. Oil should be maintained at that level.

#### **Cleaning of Coils**

In alkaline water areas, lime deposits can accumulate rapidly inside the coil pipes. This growth is increased by the extreme heat build up in the coil. The best prevention for liming conditions is to use high quality cleaning detergents. In areas where alkaline water is an extreme problem, periodic use of Coil Descaler (part #8.914-296.0) will remove lime and other deposits before coil becomes plugged.

**Periodic descaling of the heating coil is recommended so please consult your local Dealer for instructions.**

#### **Removal of Soot and Heating Coil**

In the heating process, fuel residue in the form of soot deposits may develop between the heating coil pipe and block air flow which will affect burner combustion. When soot has been detected on visual observation, the soot on the coil must be washed off after following the coil removal steps.

1. Remove the tank head assembly by unscrewing the three Tek screws and lifting the tank head off.
2. Remove the two pipe nipples and associated fittings.
3. Lift the coil out of the outer wrap.

**CAUTION: The coil weighs about 80 lbs. Use proper lifting techniques.**

**ATTENTION: La bobine pèse environ 36.2874 kg (80 lb). Utiliser des techniques de levage appropriées.**

4. Clean, repair and replace the coil by reversing the above steps.

### **Pressure Relief Valve**

Each machine is equipped with a relief valve to relieve pressure in the system when higher than normal operating pressures are encountered. Unusually high pressures come from an object plugging the spray nozzle. This problem can easily be remedied by removing the obstruction. If operating pressure of machine is found to be normal and relief valve continues to leak, repair or replace the valve.

### **Rupture Disk**

If pressure from pump or thermal expansion should exceed safe limits, the rupture disk will burst, allowing high pressure to be discharged through hose to ground. When disk ruptures, it needs to be replaced.

### **Propane Cylinder Capacity**

An important consideration with propane systems is the capacity of the supply cylinder relative to the needs of the burner. The burner operates on propane as a gas; as gas is used from the propane cylinder, the liquid in the cylinder boils to maintain gas pressure. This boiling process cools the liquid, and in a heavy, continuous-demand situation, the liquid temperature can fall to the point at which it cannot provide gas as rapidly as is needed. In this case, it may be necessary to warm the propane cylinder by directing a warm spray, not over 120° F, on the cold cylinder or by manifolding two propane bottles together to increase total vaporization capacity. It is recommended that a minimum 30 lb. vapor propane bottle be used on the machine.

**Maintenance**

**Oil Change Record**

Pump Oil - SAE 10W-40 (Non-foaming)

Date Oil Changed Month/Day/Year	Estimated Operating Hours Since Last Oil Change

Date Oil Changed Month/Day/Year	Estimated Operating Hours Since Last Oil Change

**Troubleshooting**

<b>PROBLEM</b>	<b>POSSIBLE CAUSE</b>	<b>SOLUTION</b>
<b>PULSATION</b>	Faulty pulsation damper	Check precharge. If low, recharge or install new one.
<b>LOW PRESSURE</b>	Worn nozzle	Replace with nozzle of proper size.
	Belt slippage	Tighten or replace with correct belt.
	Air leak in inlet plumbing	Disassemble, reseal and reassemble.
	Relief valve stuck, partially plugged or improperly adjusted. Valve seat worn	Clean and adjust relief valve; check for worn or dirty valve seats. Kit available.
	Inlet suction strainer clogged or improperly sized	Clean. Use adequate size. Check more frequently.
	Worn packing. Abrasives in pumped in cavitation. Inadequate water	Install proper filter. Suction at inlet manifold must be limited to lifting less than 20 feet of water or 8.5 psi vacuum.
	Fouled or dirty inlet or discharge valves	Clean inlet and discharge valve assemblies.
	Worn inlet, discharge valve blocked or dirty	Replace worn valves, valve seats and/or discharge hose.
	Leaky discharge hose	Replace.
<b>PUMP RUNS EXTREMELY ROUGH, PRESSURE VERY LOW</b>	Restricted inlet or air entering the inlet plumbing	Proper size inlet plumbing; check for air tight seal.
	Inlet restrictions and/or air leaks. Stuck inlet or discharge valve	Replace worn cup or cups. Clean out foreign material. Replace worn valves.
<b>WATER LEAKAGE FROM UNDER MANIFOLD.</b>	Worn packing	Install new packing.
<b>OIL LEAKING IN AREA OF CRANKSHAFT</b>	Worn crankshaft seal or improperly installed oil seal O-ring	Remove oil seal retainer and replace damaged O-ring and/or seals.
	Bad bearing	Replace bearing.
<b>EXCESSIVE PLAY IN END OF CRANKSHAFT PULLEY</b>	Worn main bearing from excessive tension on drive belt	Replace crankcase bearing and/or tension drive belt.
<b>WATER IN CRANKCASE</b>	Humid air condensing into water inside crankcase	Change oil intervals. Use any high grade automotive 30 weight non-detergent oil.
	Worn packing and/or piston rod sleeve; O-rings on plunger retainer worn	Replace packing. Replace O-rings.
<b>OIL LEAKING FROM UNDERSIDE OF CRANKCASE</b>	Worn crankcase piston rod seals	Replace seals.
<b>OIL LEAKING AT REAR PORTION OF CRANKCASE</b>	Worn crankcase piston rod seals	Replace seals.
<b>LOUD KNOCKING</b>	Pulley loose on crankshaft	Check key and tighten set screw.
<b>NOISE IN PUMP</b>	Broken or worn bearing	Replace bearing.

## Maintenance

PROBLEM	POSSIBLE CAUSE	SOLUTION
<b>PUMP NOISY</b>	Air in suction line	Check water supply and connections on suction line.
	Broken or weak inlet or discharge valve springs	Check and replace if necessary.
	Excessive matter in valves	Check and clean if necessary.
	Worn bearings	Check and replace if necessary.
<b>PRESENCE OF WATER IN OIL</b>	Oil seal worn	Check and replace if necessary.
	High humidity in air	Check and change oil twice as often.
<b>WATER DRIPPING FROM UNDER PUMP</b>	Piston packing worn	Check and replace if necessary.
	O-ring plunger retainer worn	Check and replace if necessary.
	Pump protector	Check inlet water pressure.
<b>OIL DRIPPING</b>	Oil seal worn	Check and replace if necessary.
<b>EXCESSIVE VIBRATION IN DELIVERY LINE</b>	Irregular functioning of the valves	Check and replace if necessary.
<b>RELIEF VALVE LEAKS WATER</b>	Wrong nozzle size, debris in nozzle	Clean or replace with correct nozzle.
<b>BURNER WILL NOT LIGHT</b>	No fuel	Open gas valve.
	Pilot light is out	Light pilot.
	Defective high limit switch	Replace switch.
<b>BURNER SMOKES</b>	Stack restriction	See venting under installation (page 7).
<b>PILOT DOES NOT LIGHT</b>	Manual pilot valve closed	Open pilot valve.
	Gas leak in pilot	Call qualified serviceman.
	Piezo ignitor	Adjust spark gap. Secure wires.
<b>PILOT IGNITES BUT WILL NOT STAY ON WHEN GAS COCK DIAL IS RELEASED</b>	Pilot too far away from thermocouple	Adjust thermocouple closer to flame.
	Thermocouple loose at regulator safety valve	Tighten to firm fit.
<b>SHORT THERMOCOUPLE LIFE</b>	Excessive heat from pilot light	Decrease pilot supply gas.
	Thermocouple too close to pilot	Adjust thermocouple farther away.
<b>BURNER CYCLING ON/OFF</b>	Defective high limit switch	Replace switch.
<b>WASHER WILL NOT STEAM</b>	Steam valve closed	Open valve (counterclockwise).
	Burner not on	Turn burner switch to "ON" position.
	Coil dirty or sooty	See coil maintenance section.
	Steam valve clogged	Clean or replace.



# Parts

**1.109-556.0**  
**VHP2-1500**

**1.109-557.0**  
**VHP3-2000**

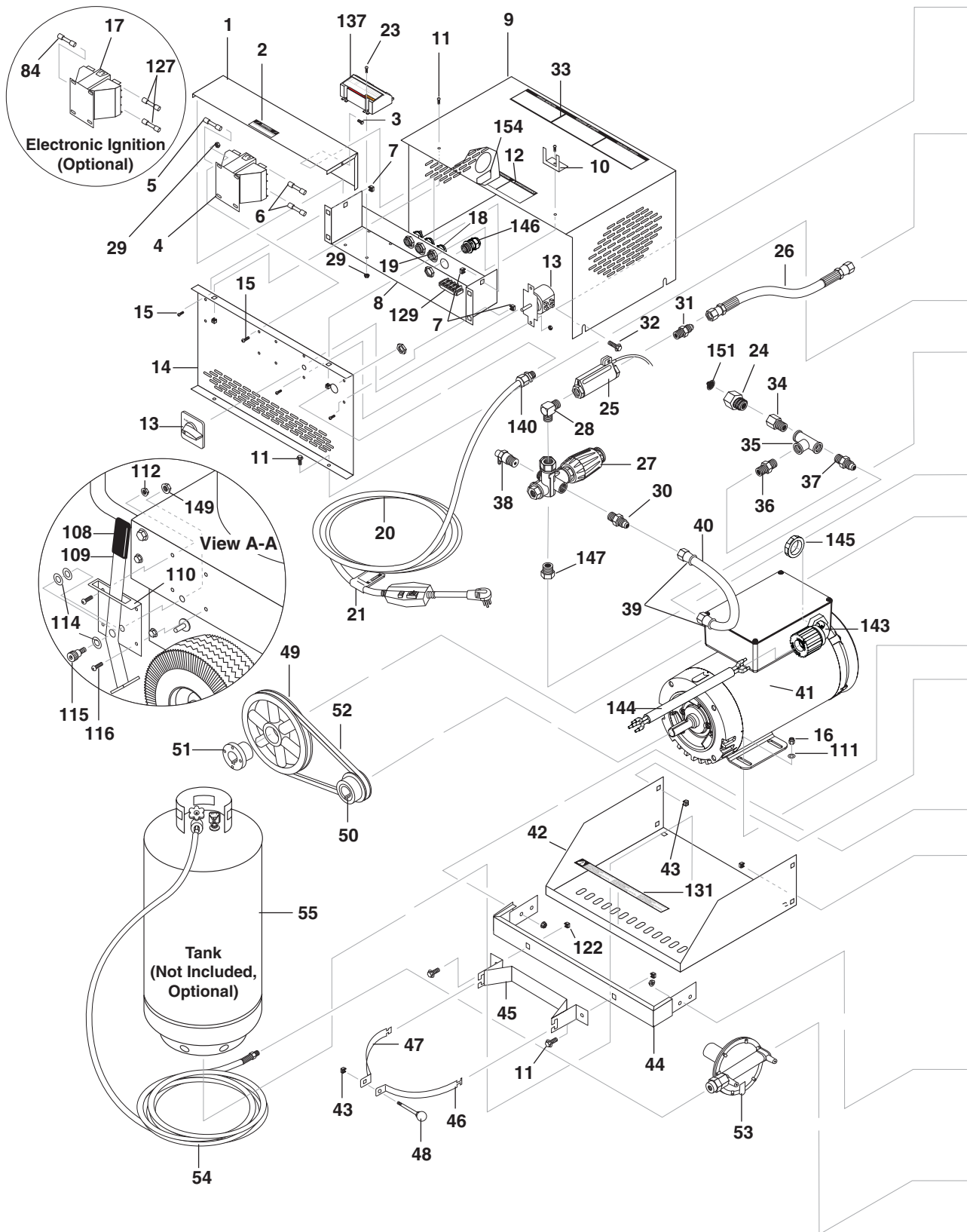

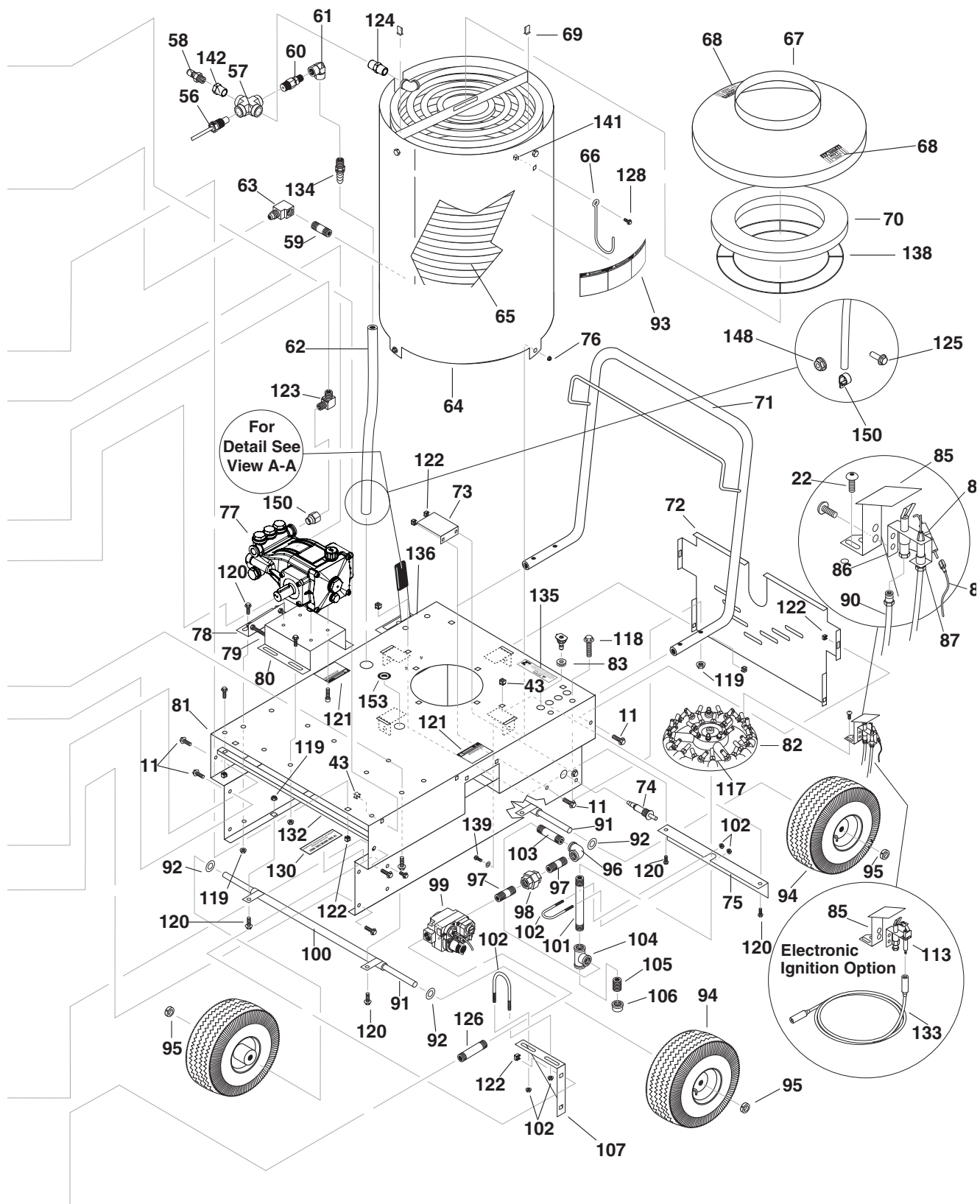

REF	PART NO.	QTY	DESCRIPTION	NOTES
1	8.912-918.0	1	COVER, ELECTRICAL BOX	
2	9.800-016.0	1	LABEL, DISCONNECT PWR SUPPLY	
3	9.802-764.0	2	SCREW, 10/32" X 3/4", HEX	
4	9.802-551.0	1	TRANSFORMER 240/480V - 120V	(3-2000)
5	8.716-173.0	1	FUSE, PAPER 1 AMP 250V MIDGET	(3-2000)
6	8.933-007.0	2	FUSE, 1 AMP 600V MIDGET	(3-2000)
7	9.802-791.0	6	NUT, CAGE, 10/32 X 16 GA	
8	8.912-917.0	1	BOX, ELECTRICAL, VHW, BELT	
-	9.802-762.0	1	SCREW, 10/32" X 1-1/4"	NOT SHOWN
-	9.802-695.0	6	NUT, 10/32" KEPS	NOT SHOWN
-	-	10	NUT, 10/32" KEPS	(ELECTRONIC IGNITION)
-	9.800-040.0	1	LABEL, GROUND	NOT SHOWN
9	8.912-919.0	1	COVER, PUMP & MOTOR, VHW BELT	
10	8.912-888.0	1	HOLDER, WAND BRACKET, VHW/VHP	
11	9.802-754.0	16	SCREW, 1/4" X 1/2", HH NC, WHIZ LOC	
12	9.800-033.0	1	LABEL, WARNING HOT WATER	
13	9.802-449.0	1	SWITCH, 3 PS, 115V-230V, 1 PH	
14	8.912-916.0	1	PANEL, CONTROL, VHW, BELT	
15	9.802-759.0	8	SCREW, 10/32" X 1/2" BHSOC BLK	
-	-	12	SCREW, 10/32" X 1/2" BHSOC BLK	(ELECTRONIC IGNITION)
16	9.802-776.0	5	NUT, 5/16", ESNA, NC	
17	9.802-553.0	1	TRANSFORMER, 120/240 -24V .050 KVA	(ELECTRONIC IGNITION OPTION)
18	9.802-514.0	3	STRAIN RELIEF, 1/2" LQ TITE	
19	9.802-525.0	3	LOCKNUT, 1/2"	
20	9.802-433.0	1	PLUG, GFCI, 240V, 20 AMP	(3-2000)
-	9.802-431.0	1	CORD W/GFCI, 120V 20 AMPS	(2-1500)
21	8.932-969.0	1	LABEL, WARNING, SERVICE CORD	
22	9.802-772.0	2	SCREW, 10/32" X 1/4"	
23	9.802-771.0	4	SCREW, 10/32" X 3/4"	
24	8.757-203.0	1	SWIVEL, 1/2" M-NPTF x 3/4" GHF	
25	8.933-006.0	1	SWITCH FLOW MV 60, YELLOW	
26	8.918-210.0	1	HOSE, 3/8" X 16", 2 WIRE, PRESSURE LOOP	
27	8.750-299.0	1	UNLOADER, VRT 3, 8 GPM @4500 PSI	
28	8.757-621.0	1	Elbow 3/8 BSPP (M) x 3/8 NPTF (M) 90°	
29	9.802-695.0	8	NUT, 10/32" KEPS	
30	8.758-007.0	1	Adapter brass 1/2 JIC (M) x 3/8 NPTF (M)	
31	8.756-875.0	1	Adapter steel 1/2 JIC (M) x 3/8 BSPP (M)	
32	9.802-767.0	4	SCREW, 3/8" X 3/4" WHIZ LOC	
33	8.900-822.0	1	LABEL, VHP OPERATING INSTR.	
34	8.757-193.0	1	ADAPTER, 1/2" F-NPTF x 1/2" M-NPTF, BRASS	
35	8.757-485.0	1	TEE, 1/2", BRASS	
36	8.757-619.0	1	Adapter 1/2 BSPP (M) x 1/2 NPTF (M)	
37	8.757-200.0	1	Adapter brass 1/2 SAE (M) x 1/2 NPTF (M)	

REF	PART NO.	QTY	DESCRIPTION	NOTES
38	8.707-254.0	1	PUMP PROTECTOR, 3/8" PTP	
39	9.802-151.0	2	SWIVEL, 1/2" JIC FEM, PUSH-ON	
40	9.802-259.0	12"	HOSE, 1/2" PUSH-ON	
41	8.754-710.0	1	MOTOR, 2 HP, 1 PH 3470 RPM, C-FACE	(2-1500)
-	9.802-341.0	1	MOTOR, 5 HP 1 PH 3450 RPM C-FACE	(3-2000)
-	9.800-032.0	1	LABEL, MOTOR OVERLOAD RESET, LEXAN	NOT SHOWN
42	8.912-873.0	1	SUPPORT, PROPANE TANK, VHP	
43	9.802-792.0	16	NUT, CAGE, 3/8" X 12 GA.	
44	8.912-864.0	1	BRACE, LP BOTTLE, VHP	
45	8.912-879.0	1	BRACKET, PROPANE TANK, VHP	
46	8.912-882.0	1	STRAP, PROPANE TANK, R/H VHP	
47	8.912-885.0	1	STRAP, PROPANE TANK, L/H VHP	
48	8.719-063.0	1	KNOB, 3/8" - 16 X 1-1/2" VHP	
49	9.804-029.0	1	PULLEY, AK64H	(2-15024D)
-	9.802-380.0	1	PULLEY, BK80H	(3-20024A)
50	8.715-516.0	1	PULLEY, BORE, AK 20 X 5/8	(2-15024D)
-	9.802-377.0	1	PULLEY, BK32	(3-20024A)
-	9.803-897.0	1	BUSHING, H X 3/4	NOT SHOWN (3-20024A)
51	9.802-402.0	1	BUSHING, HX24MM	
52	9.804-026.0	1	BELT, AX31	(2-15024D)
-	8.715-695.0	1	BELT, BX34	(3-20024A)
53	8.717-749.0	1	REGULATOR, PROPANE, R532CFF	
54	8.711-851.0	1	HOSE, 3/8" X 10', PROPANE ASSEMBLY	
55	8.717-790.0	1	TANK, PROPANE 10.5 GAL. 30 LB. W/ GAUGE	OPTIONAL
56	8.712-185.0	1	SWITCH, SNAP, 225 DR HI-LIMIT	
57	8.757-704.0	1	CROSS FEMALE STEEL 1/2"	
58	9.802-171.0	1	NIPPLE, 3/8" X 3/8" NPT ST MALE	
59	8.757-405.0	1	NIPPLE STEEL 1/2" X 2-1/2" SCH 80 W/SLNT	
60	8.707-381.0	1	RUPTURE DISC ASSY, 8500#	
61	8.757-903.0	1	ELBOW STEEL 3/8 NPTF (F)	
62	9.802-259.0	30"	HOSE, 1/2", PUSH-ON	
63	8.757-363.0	1	ELBOW STEEL 1/2 JIC (M) X 1/2 NPTF (F)	
64	8.915-908.0	1	WRAP, OUTER COIL, SS	
-	9.800-021.0	1	LABEL, HOT WATER OUTLET	NOT SHOWN
65	9.803-134.0	1	COIL, DURA, 14.5" DIA, SCH 80	
66	8.719-968.0	1	HOLDER, WAND, VHW/VHP ZINC PLATED	
67	9.803-029.0	1	TANK HEAD ASSEMBLY, 16" DIA X 8" STACK	
67	9.802-797.0	2	SCREW, #10 X 1/2" HEX HEAD TEK SS	NOT SHOWN
68	9.800-006.0	2	LABEL, "HOT/CALIENTE" W/ARROWS	
69	9.802-825.0	4	RETAINER CLIP	
70	9.802-904.0	1	INSULATION, TANK HEAD 16" OD X 8" ID	
71	8.912-899.0	1	HANDLE, VHW/VHP/MVP W/HNG	
72	8.912-871.0	1	PANEL, CHASSIS, FRONT/BACK	
73	8.912-881.0	1	REFLECTOR, PILOT LIGHT, VHP/VHG	

REF	PART NO.	QTY	DESCRIPTION	NOTES
74	9.802-678.0	1	IGNITOR, PIEZO	
75	8.912-875.0	1	SUPPORT, BURNER RING	
76	9.802-778.0	4	NUT, WHIZ LOC 5/16 FLANGE	
77	8.923-809.0	1	PUMP, LEGACY GB3030R, 3.0@3000, 1650 RPM	
78	8.912-920.0	1	RETAINER, TAKE-UP, PUMP	
79	9.802-733.0	2	BOLT, 3/8" X 3-1/2" TAP	
80	9.803-131.0	1	RAIL, PUMP COMBO	
81	8.912-923.0	1	BASE, MAIN, VHP, BELT	3-2000
-	8.924-182.0	1	WLMT, BASE, VHP -15	2-1500
82	8.718-054.0	1	BURNER RING, X-11 W/640-69 JET ORIFICES	
83	9.802-064.0	1	GROMMET, RUBBER, NOZZLE HOLDER	
84	9.802-463.0	1	FUSE, PAPER, BUSS FNM-1/2 250V MIDGET TD	(ELECTRONIC IGNITION OPTION)
85	8.912-890.0	1	BRACKET, PILOT LIGHT, VHP/VHG	
-	8.719-957.0	1	BRACKET, PILOT LIGHT, VNG-S(ELECTRIC IGNITION)	
86	8.718-150.0	1	PILOT, VHP	
-	8.718-075.0	1	ORIFICE, PILOT, LP, SMALL	NOT SHOWN
87	8.718-092.0	1	THERMOCOUPLE, 24" WHITE RODGERS	
88	9.802-681.0	1	WIRE, 15" ASSEMBLY	
-	9.802-682.0	1	TCB, GND	NOT SHOWN
89	8.718-069.0	1	ELECTRODE, PIEZO ASSEMBLY	
90	9.802-911.0	36"	TUBING, ALUMINUM, 1/4" DEADSOFT	
91	8.912-868.0	2	AXLE, 23", VHW	
92	9.802-810.0	4	WASHER, 5/8", FLAT, SAE	
93	9.800-031.0	1	LABEL, VHP PILOT LIGHT	
94	8.754-186.0	4	QH WHEEL ASSY, 10" GRAY STEEL W/TUB	
95	9.802-782.0	4	COLLAR, 5/8" BORE SHAFT	
96	9.802-027.0	1	ELBOW, 3/4", BLACK, 90°	
97	9.802-018.0	2	NIPPLE, 3/4" X 3". BLACK PIPE	
98	9.802-049.0	1	UNION, 3/4", BLACK PIPE	
99	8.718-045.0	1	VALVE, GAS, WR 36103A-410, 3/4"	
-	9.803-616.0	1	VALVE, GAS	(ELEC. IGN.) NOT SHOWN
-	9.803-618.0	1	LP, CONVERT KIT, ELEC IGN	NOT SHOWN
100	8.912-858.0	2	AXLE, HOLDER ASSEMBLY VHW/VHP	
101	8.706-108.0	1	NIPPLE, BLK, PIPE 3/4" X 3-1/2"	
102	8.718-648.0	2	U-BOLT, 1/4" X 1-1/2" X 2-1/2" W/PLATE	
103	8.706-108.0	1	NIPPLE, 3/4" X 3-1/2", BLACK PIPE	
104	8.706-222.0	1	TEE, 3/4" NLK PIPE	
105	9.802-018.0	1	NIPPLE, 3/4" X 3", BLACK PIPE	
106	8.706-320.0	1	CAP, 3/4", BLACK PIPE	
107	8.912-877.0	1	SUPPORT, GAS TRAIN, VHP/VHG	
108	9.804-608.0	1	CAP, VINYL FKT (YELLOW)	
109	8.912-930.0	1	ASSY, LEVER BRAKE	
110	8.912-928.0	1	BRACKET, WHEEL BRAKE	
111	8.718-980.0	12	WASHER, 5/16", FLAT, SAE	
112	9.802-775.0	8	NUT, 1/4" FLANGE, WHIZ LOC	
113	9.803-610.0	1	PILOT, IGNITOR	(ELECTRIC IGNITION)

REF	PART NO.	QTY	DESCRIPTION	NOTES
114	9.802-807.0	8	WASHER, 3/8", SAE, FLAT	
115	8.718-785.0	1	SCREW, 3/8" X 3/8", SCKT	
116	9.802-765.0	4	SCREW, 1/4" X 1/2" BH SOL CS	
117	9.802-684.0	32	JET ORIFICE #69, DRILL TO #66	
118	9.802-769.0	4	SCREW, 3/8" X 1-3/4" WHIZ LOC	
119	9.802-781.0	11	NUT, 3/8" FLANGE WHIZ LOC	
120	9.802-767.0	18	SCREW, 3/8" X 3/4" WHIZ LOC	
121	8.932-965.0	2	LABEL, EXPOSED PULLEY	
122	9.802-794.0	10	NUT, CAGE, 1/4" X 12 GA	
123	8.757-340.0	1	ELBOW 3/8", STREET 90 DEG, STEEL, W/SLNT	
124	8.757-338.0	1	NIPPLE, 1/2" HEX STEEL, W/SLNT	
125	9.802-753.0	1	SCREW 1/4"-20 X 3/4" FLANGE	
126	8.706-109.0	1	NIPPLE, 3/8" X 7", BLACK PIPE	
127	8.933-007.0	2	FUSE, KTK-R1 600V MIDGET FUSE	(ELECTRONIC IGNITION OPTION)
128	9.802-753.0	5	SCREW, 1/4" X 3/4", WHIZ LOC	
129	9.802-491.0	1	BLOCK TERMINAL, 4 POLE	(ELECTRONIC IGNITION)
130	8.932-963.0	1	LABEL, LIQUID PROPANE	
131	8.900-829.0	1	LABEL, VHP, PROPANE TANK	
132	8.912-894.0	1	BRACE, CHASSIS	
133	9.803-562.0	1	CABLE, IGNITION, 48"	(ELECTRONIC IGNITION)
134	8.757-487.0	1	HOSE BARB, 1/2" BARB X 3/8", BRASS	
135	9.800-018.0	1	LABEL, TIPOVER HAZARD	
136	9.800-049.0	1	LABEL, MANUFACTURER'S CLEANING SOLUTIONS	
137	9.803-613.0	1	MODULE, IGNITION, ELECTRONIC	
138	9.803-108.0	1	RETAINER RING, INSULATION	
139	8.718-618.0	4	BOLT, 5/16" X 3/4" NC	
140	9.802-518.0	1	STRAIN RELIEF 3/4	
141	9.802-793.0	5	NUT, CAGE, 1/4" X 16 GA	
142	8.757-513.0	1	BUSHING, 1/2"NPTF(M) X 3/8"NPTF(F),STEEL	
143	8.755-957.0	1	STRAIN RELIEF, 3/4", 90DEG, BLK	
144	9.802-427.0	2.75 FT	CORD, SERV, 12/3, SEOOW, /FT	
145	9.802-523.0	1	LOCKNUT, 3/4" CONDUIT	
146	9.802-518.0	1	STRAIN RELIEF, STR, 3/4	
147	8.757-905.0	1	NIPPLE HEX STEEL 3/8 NPTF (M)	
148	9.802-775.0	1	NUT, 1/4" FLANGE	
149	9.802-779.0	1	NUT, 3/8", ESNA, NC	
150	8.709-090.0	1	CLAMP, WIRE/TUBE, 0.75	
151	9.804-016.0	1	FILTER SCREEN WASHER, GARDEN HOSE/30MESH	
152	8.757-184.0	1	ADAPTER STEEL 3/8 NPTF(F) X 3/8 BSPP(M)	
153	9.802-103.0	1	BUSHING, 5/8" SNAP	
154	9.800-020.0	1	LABEL, COLD WATER INLET	

# Hose & Spray Gun

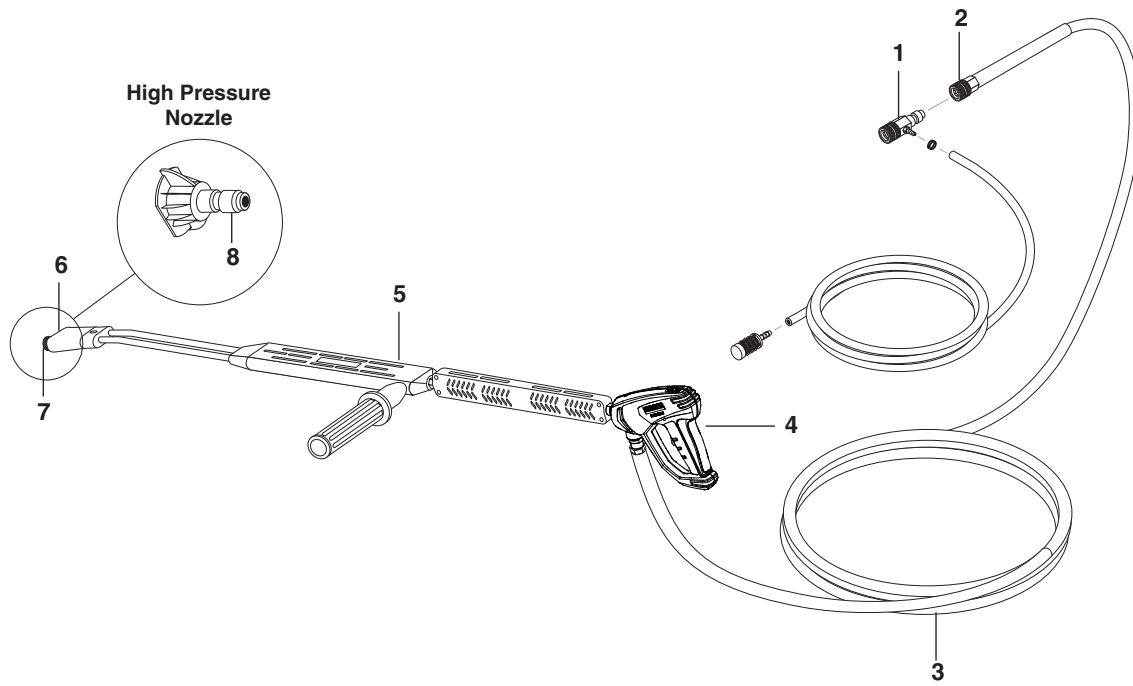



REF	PART NO.	QTY	DESCRIPTION	NOTES
1	8.756-796.0	1	INJECTOR, CHEMICAL, NON ADJ 0.070(1.8MM)	
2	9.802-166.0	1	COUPLER, 3/8" FEMALE	
-	9.802-100.0	1	QUICK COUPLER O-RING, 3/8"	
3	8.739-026.0	1	HOSE, 3/8" X 50', 1-WIRE, TUFF-SKIN	
4	4.775-054.0	1	EASY! FORCE ADVANCED KNA	
5	8.711-293.0	1	WAND, ONLY, VP, ZINC	
6	9.802-286.0	1	BRASS SOAP NOZZLE, 1/8"	
7	9.802-165.0	1	COUPLER, 1/4" MALE, BRASS	
-	9.802-096.0	1	QUICK COUPLER O-RING, 1/4"	
8	8.712-333.0	1	NOZZLE, SAQCMEG 1503, YELLOW	(2-1500)
-	8.712-338.0	1	NOZZLE, SAQCMEG, 15035, YELLOW	(3-2000)
9	8.707-139.0	1	COUPLER, 1/4" PLUG, MALE, STEEL/ZINC	NOT SHOWN
10	9.802-164.0	1	COUPLER, 1/4" SOCKET, FEMALE, BRASS	NOT SHOWN

3-2000

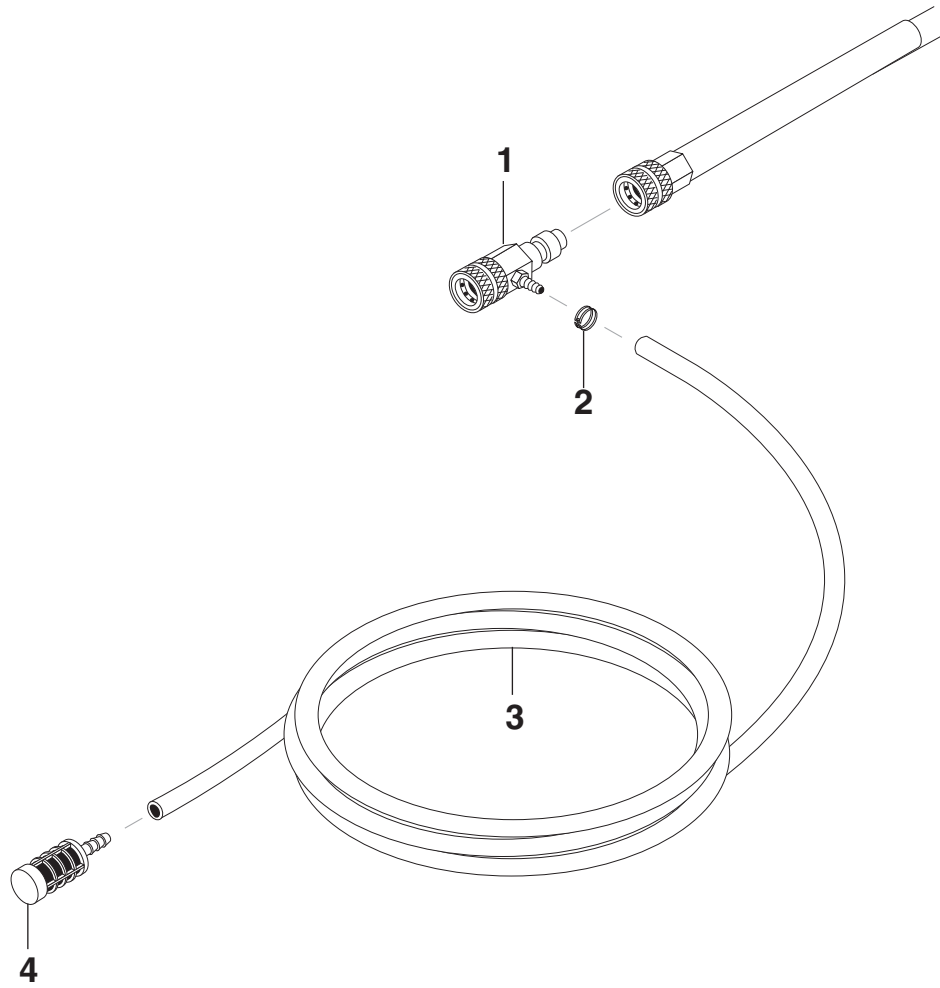

<b>REF</b>	<b>PART NO.</b>	<b>QTY</b>	<b>DESCRIPTION</b>	<b>NOTES</b>
1	9.802-215.0	1	INJECTOR, DETERGENT, NON ADJUST, #2, 2-3 GPM	
2	6.390-126.0	1	CLAMP, HOSE, .46-, .54 ST	
3	9.802-251.0	6 ft.	TUBE, 1/4" X 1/2", CLEAR VINYL	
4	8.707-057.0	1	STRAINER, 1/4", HOSE BARB	

# G3 Evolution

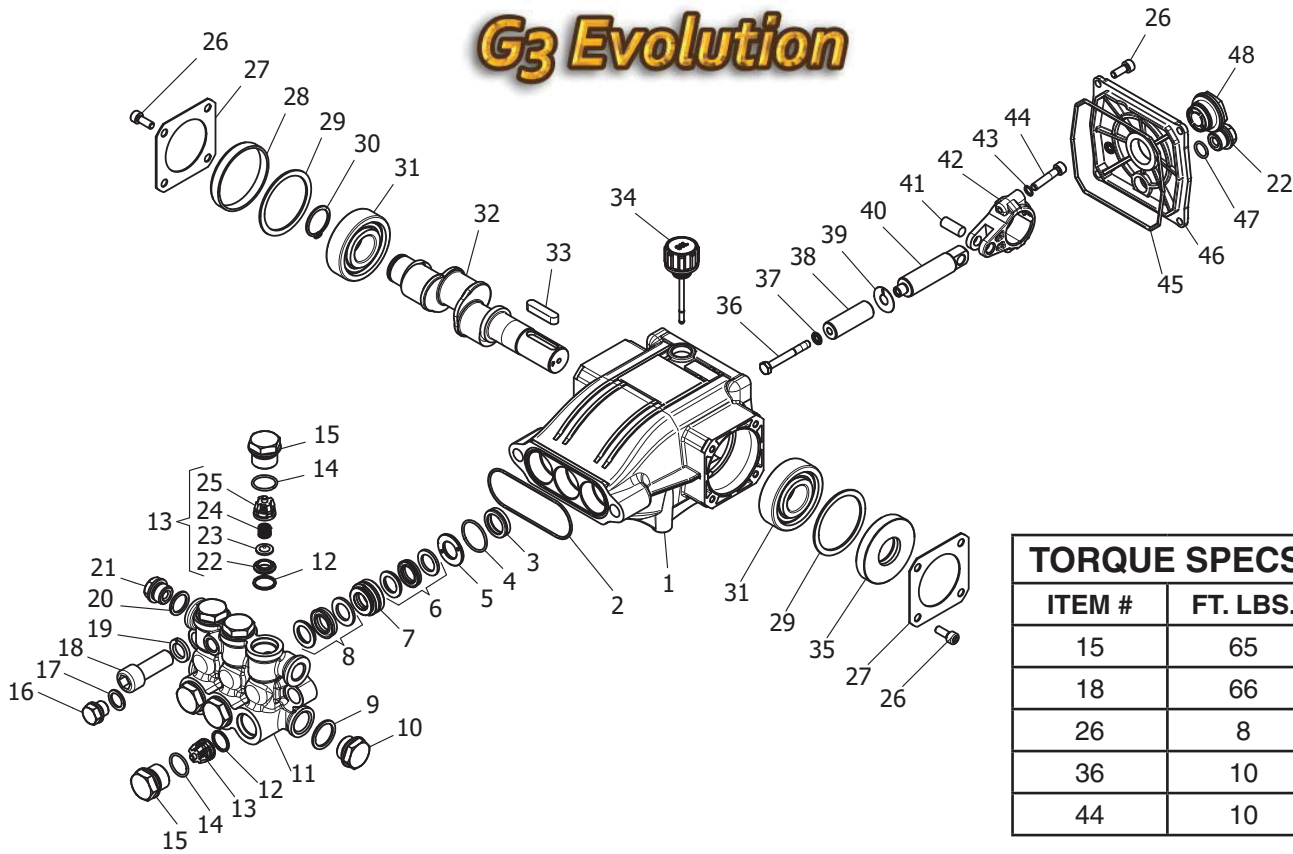

REF	PART NO.	QTY	DESCRIPTION	NOTES
1	8.754-841.0	1	CRANKCASE	
2	8.754-846.0	1	O-RING Ø1.78 X 72.75	
3	-	3	PLUNGER OIL SEAL	SEE TABLE KITS
4	-	3	O-RING Ø1.78 X 26.7	SEE TABLE KITS
5	-	3	WASHER, PRESSURE RING 16 MM	SEE TABLE KITS
6	-	3	U-SEAL, 16 MM	SEE TABLE KITS
7	-	3	PRESSURE RING, 16 MM	SEE TABLE KITS
8	9.803-199.0	3	U-SEAL, 16 MM	SEE TABLE KITS
9	9.803-199.0	1	WASHER, COPPER G1/2	
10	9.802-926.0	1	PLUG, BRASS G1/2	
11	8.754-852.0	1	MANIFOLD	
12	8.717-233.0	6	O-RING Ø1.78 X 15.6	SEE TABLE KITS
13	-	6	VALVE ASSEMBLY	SEE TABLE KITS
14	9.803-948.0	6	O-RING Ø1.78 X 18.77	SEE TABLE KITS
15	9.803-949.0	6	VALVE PLUG	
16	8.754-851.0	1	PLUG, BRASS G1/4	
17	8.718-973.0	1	WASHER, COPPER G1/4	
18	8.754-854.0	2	BOLT, MANIFOLD M14 X 40	
19	8.754-850.0	2	WASHER, LOCK	

REF	PART NO.	QTY	DESCRIPTION	NOTES
20	9.803-198.0	1	WASHER, COPPER G3/8	
21	8.707-262.0	2	PLUG, BRASS G3/8	
22	-	6	VALVE SEAT	SEE TABLE KITS
23	-	6	VALVE PLATE	SEE TABLE KITS
24	-	6	VALVE SPRING	SEE TABLE KITS
25	-	6	VALVE CAGE	SEE TABLE KITS
26	9.802-939.0	12	SCREW, M6 X 16	
27	8.717-137.0	2	BEARING COVER	
28	9.803-954.0	1	BEARING SEAL	
29	8.754-843.0	2	SEAL SPACER, CRANKSHAFT	
30	9.802-914.0	1	SNAP RING, 25 MM	
31	9.803-955.0	2	BEARING, BALL	
32	8.754-829.0	1	SHAFT, 24 MM 3030	
-	8.754-830.0	1	SHAFT, 24 MM 4025	
33	9.803-167.0	1	KEY, CRANKSHAFT	
34	8.754-219.0	1	OIL DIPSTICK	
35	8.933-010.0	1	SEAL, CRANKSHAFT	
36	8.754-855.0	3	BOLT, PLUNGER	SEE TABLE KITS
37	8.754-092.0	3	SPACER, COPPER	SEE TABLE KITS
38	8.754-848.0	3	PLUNGER, 16 MM	SEE TABLE KITS
39	9.803-962.0	3	SPACER, COPPER	SEE TABLE KITS
40	8.754-827.0	3	PLUNGER ROD	
41	9.803-965.0	3	CONNECTING ROD PIN	
42	9.803-966.0	3	CONNECTING ROD	
43	9.803-218.0	6	WASHER, 6 MM	
44	8.933-020.0	6	SCREW, CONNECTING ROD	
45	8.754-847.0	1	O-RING Ø2.62 X 111.62	
46	8.754-842.0	1	COVER, CRANKCASE	
47	9.803-906.0	1	O-RING Ø1.78 X 14	
48	9.803-202.0	1	SIGHT GLASS, G3/4	

KIT NUMBERS	8.754-856.0	8.754-857.0	8.754-858.0	8.754-859.0	9.803-937.0
KIT DESCRIPTION	Plunger Seals 16 mm	Seal Packing 16 mm	Plunger 16 mm	Complete Valve	Plunger Oil Seals
ITEM NUMBERS INCLUDED	4, 6, 8	4, 5, 6, 7, 8	36, 37, 38, 39	12, 13, 14	3
NUMBER OF CYLINDERS KIT WILL SERVICE	3	1	1	6	3

## VRT3 Unloader

8.750-297.0, 8 GPM, 2320 PSI

8.750-298.0, 8 GPM, 3630 PSI

8.750-299.0, 8 GPM, 4500 PSI

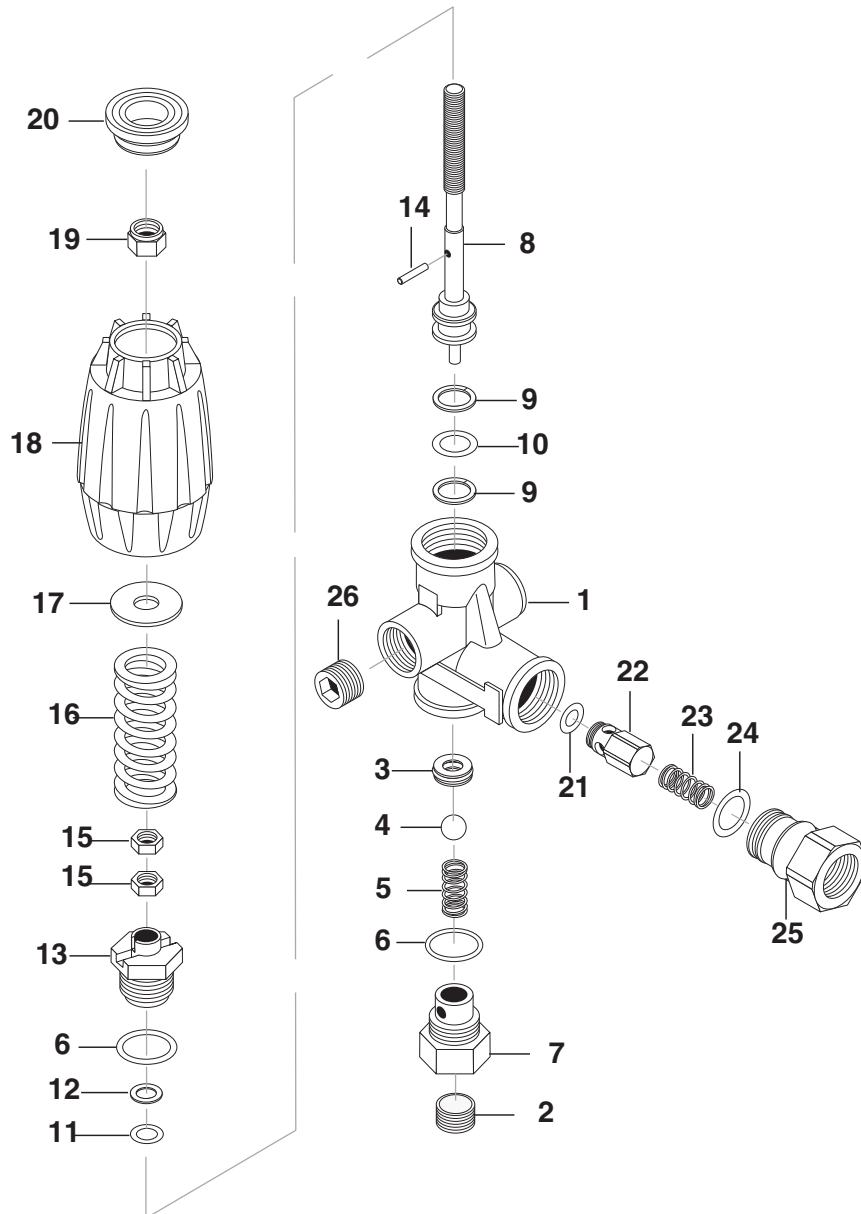

REF	PART NO.	QTY	DESCRIPTION	NOTES
25	8.750-713.0	1	OUTLET FITTING	
18	8.750-712.0	1	KNOB, UNLOADER	
-	8.750-709.0	-	REPAIR KIT, VRT3, 2320/3630 PSI	
-	8.750-710.0	-	REPAIR KIT, VRT3, 4500 PSI	
-	-	-	(KIT ITEMS: 3, 4, 6, 9-12, 21, 24)	

## Unloader Adjustment Procedures

1. Remove lock nut (Item 19).
2. Remove adjustment knob (Item 18).
3. Loosen the two (2) nuts (Item 15), move them upward on stem (Item 8) until you see 4 or more threads below the nut.
4. Re-attach adjusting knob (Item 18).
5. Start machine. Open the trigger of the spray gun. Increase pressure by turning adjustment knob (Item 18) clockwise until pressure is at the desired operating pressure.
6. Remove the adjustment knob (Item 18), tighten the lower nut (Item 15) tightly against the upper nut (Item 15). Re-attach adjustment knob (Item 18) and screw down until contact is made with the nuts (Items 15). Screw down lock nut (Item 19) onto the stem (Item 8) until the threads cut into the nylon insert of the lock nut (Item 19).

\*If adjustment knob (Item 18) **DOES NOT** make contact with upper nut (Items 15), remove adjusting knob (Item 18), re-adjust (raise) nuts (Items 15) on stem (Item 8) and re-attach adjustment knob (Item 18), then repeat step #6.

\*\*If adjustment knob (Item 18) **DOES** make contact with upper nut; release the trigger of the spray gun and watch the pressure gauge for the pressure increase (“spike”). This “spike” **SHOULD NOT** exceed 500 psi above the operating pressure. If “spike” pressure exceeds the 500 psi limit, remove the adjusting knob (Item 18) and re-adjust (lower) the nuts (Items 15) on the stem (Item 8). Re-attach the adjusting knob (Item 18), then repeat step #6.

Gracias por comprar un Lavadora a Presión.

Estas instrucciones y advertencias corresponden a los modelos VHP.

Se reserva el derecho de hacer cualquier cambio en cualquier momento sin contraer ninguna obligación.

### Responsabilidades del Dueño/Usuario:

El dueño y/o usuario debe estar al tanto de las instrucciones de operación y de las advertencias del fabricante antes de usar su lavadora a presión. La información de advertencia debe ser enfatizada y comprendida. Si el operador no domina el inglés, el comprador/dueño deberá leer y discutir con éste las instrucciones y las advertencias del fabricante en el idioma natal del operador, asegurándose de que éste entienda su contenido.

El dueño y/o usuario debe estudiar y mantener las instrucciones del fabricante para futuras referencias.

### CUIDAR ESTAS INSTRUCCIONES

**Este manual debe ser considerado una parte permanente de la máquina y debe quedarse consigo si máquina es revendida. Al ordenar las partes, especifican por modelo y número de serie. Utilice repuestos sólo idénticos. Esta máquina debe ser utilizada solamente por los operadores entrenados.**

### Seguridad De La Maquina



**PRECAUCION:** Para reducir el riesgo de accidentes, lea las instrucciones cuidadosamente antes de usar la unidad.

1. Lea todo el manual para operadores cuidadosamente. Al no seguir las instrucciones puede causar el mal funcionamiento de la unidad y provocar la muerte, o causar serias heridas y/o daños en la propiedad.
2. Todas las instalaciones deben cumplir con los códigos locales. Póngase en contacto con un técnico eléctrico, plomero, compañía de servicios públicos o distribuidor de ventas para mayores detalles.



**ADVERTENCIA: Riesgo de asfixia. Use este producto solo en áreas bien ventiladas.**

3. Evite instalar unidades en áreas pequeñas o cerca de ventiladores de gases de escape. Los gases de escape contienen gas venenoso de monóxido de carbono; la exposición puede causar pérdida del conocimiento

y causar la muerte. Los gases de escape también contienen químicos, en ciertas cantidades, que se sabe, causan cáncer, defectos de nacimiento, o daños al sistema reproductivo.



**ADVERTENCIA: Líquidos inflamables pueden crear gases que se encienden causando daños a la propiedad y heridas severas.**

4. Aparatos de encendido con petróleo deberán de ser instalados en lugares donde residuos de combustibles, vapores o gases inflamables no estén

normalmente presentes. En modelos de encendido con petróleo utilice únicamente kerosene #1 o diesel. No utilice gasolina, solventes o alcohol. El utilizarlo resultará en fuego y/o explosión.



**ADVERTENCIA: Mantenga el chorro de agua, la varilla y la manguera de alta presión lejos del cableado eléctrico ya que puede ocurrir un choque fatal. Lea la etiqueta de advertencia del cable eléctrico.**

5. Para proteger al operador de un choque eléctrico, la máquina deberá de estar conectada a

tierra. Es la responsabilidad del dueño de conectar esta máquina a un receptáculo a tierra aprobado por UL con el amperage y voltaje indicados. No moje sobre o cerca de los componentes eléctricos; no toque la máquina con las manos mojadas o cuando esté parado sobre agua. Siempre desconecte la máquina cuando le dé servicio de mantenimiento.



**ADVERTENCIA: Sostenga la pistona aspersora con ambas manos ya que con la alta presión esta puede tener retroceso.**

6. Sujete firmemente con ambas manos la varilla aspersora antes de encender la maquina; de no seguir esta recomendación puede resultar en heridas por golpe de la misma.
7. No coloque la máquina cerca de objetos inflamables si el motor esta caliente.



**ADVERTENCIA: Este equipo puede producir un fluido de alta presión a chorro que puede penetrar la piel y sus tejidos, causando graves heridas y posible amputación.**

8. No reemplazar el tanque de propano líquido mientras la unidad está funcionando. Podrían ocurrir accidentes serios.



**ADVERTENCIA: Usar combustible líquido solamente.**

9. Este equipo está diseñado para funcionar a gas. No usar combustible líquido. Disponer de un técnico de servicio calificado para instalar y proveer servicio de mantenimiento a su equipo.

10. El agua de ingreso debe estar fría.
11. No operar el equipo cuando se esté fatigado o bajo la influencia de alcohol o drogas. Mantener el área de operación libre de personas.
12. Nunca producir chispas o llamas donde exista la presencia de gas.
13. Nunca intentar encender el piloto a menos que la válvula manual haya estado cerrada por 5 minutos.
14. Nunca operar la máquina con el tanque de propano líquido colocado en el soporte. Retirar el tanque de propano líquido de la máquina tan lejos como lo permita la manguera.
15. Los gases de propano líquido son más pesados que el aire y se esparcirán sobre el piso. Proveer siempre espacio y ventilación adecuados alrededor de estas unidades.
16. Durante las reparaciones, desconectar el suministro eléctrico y cerrar la válvula de gas.

17. Apagar el quemador, abrir la pistola de paso y enfriar hasta 100° F antes de apagar la máquina.
18. La máquina no debe estar desatendida durante la operación.
19. No adecuada para conectar un respiradero de gas Tipo B, si la temperatura de la chimenea excede 243° C (470° F).
20. Sila máquina va a ser instalada en forma permanente, instalar una campana de tiro con la descarga de gases fuera del edificio.



**Advertencia: Si Se Percibe Olor A Gas, Cerrar El Suministro De Gas.**

21. Si se percibe olor a gas, cerrar el suministro de gas, apagar toda llama abierta y revisar las uniones aplicando una solución de jabón. Si el olor persiste, llamar a su proveedor de gas inmediatamente.

### Instalación

Colocar la máquina en una ubicación conveniente, con amplio apoyo, drenaje y espacio para servicio de mantenimiento.

**Este equipo es para uso en interior.**

### Ubicación:

La ubicación deberá proteger la máquina de las condiciones perjudiciales del medio ambiente, tales como viento, lluvia y congelamiento.

1. La máquina deberá funcionar en una superficie nivelada donde no sufra la influencia de factores externos tales como vientos fuertes, temperaturas de congelamiento, lluvia, etc. Al seleccionar la ubicación, considerar accesibilidad para reemplazar Tanques de propano líquido, reabastecer detergentes, reajustes y mantenimiento. El operador deberá tomar precauciones para prevenir los excesos de humedad que puedan afectar los componentes eléctricos.
2. Es recomendable hacer una partición entre el área de lavado y la máquina para prevenir el rociado directo de la pistola cuando está en contacto con la máquina. La humedad excesiva en los controles eléctricos reducirá la vida útil de la unidad y podría causar cortocircuitos.
3. Durante el montaje, evitar áreas con ventilación insuficiente o áreas donde los ventiladores generen insuficiente suministro de oxígeno. Se puede obtener una buena combustión, solamente cuando hay suficiente suministro de oxígeno disponible para la cantidad de combustible incinerado. Si se instala en una área con ventilación insuficiente, suministrar aire fresco exterior al quemador con un ventilador instalado dentro del ambiente. Evitar espacios estrechos o áreas cerca de ventiladores.

### Regulaciones Sobre Gases:

Consultar con la compañía de gas local y con las autoridades municipales respecto a las normas o regulaciones específicas que rijan el montaje. El montaje debe hacerse de acuerdo con las regulaciones municipales locales.

### Aspecto Eléctrico:

Esta máquina, al ser instalada, debe ser puesta a tierra según las regulaciones municipales locales. Verificar el adecuado suministro de energía usando un voltímetro.

El voltímetro VHP2-15021D requiere un receptáculo de 20 amp para cumplir con los estándares de certificación UL 1776.

### Respiradero:

Cuando la lavadora a presión es instalada en un espacio muy estrecho sin aberturas de ventilación al exterior, deben tomarse medidas para suministrar aire de combustión a través de aberturas especiales, una cerca del piso y otra cerca del techo; cada una medida en base a una pulgada cuadrada o más de área libre por cada 1,000 BTU de consumo por hora.

### Colocación:

No colocar la máquina cerca de materiales combustibles. Mantener todo material inflamable a 20 pies de distancia por lo menos.

Permitir suficiente espacio para dar servicio de mantenimiento a la unidad.

Regulaciones municipales locales requieren mantener ciertas distancias entre el piso y las paredes.

(Dos pies de distancia deberían ser suficientes.)

### Suministro de Agua:

El suministro de agua para la unidad deberá ser provisto por una manguera de jardín de 5/8" de diámetro interno con una presión de agua local no menor a 30 psi. Si el suministro de agua es insuficiente, o si la manguera está torcida, la unidad funcionará mal y el quemador no arrancará.

### Conexión:

Conectar la varilla, boquilla y pistola (como corresponda). En las conexiones de tubería de rosca, usar cinta de teflón para evitar fugas de agua. (Ver Identificación del Componente.)

Conectar la manguera de alta presión al niple de descarga jalando el collar de acoplamiento hacia atrás e insertándolo en el niple de descarga. Luego, empujar el collar hacia adelante para asegurarlo. Un inyector detergente podría ser insertado entre el acoplamiento de la manguera y el niple de descarga.

Colocar el tubo de productos detergentes en el jabón líquido o solución detergente. Evitar que el tubo succione aire.

***PRECAUCION: Al instalar la manguera de gas propano al Tanque de propano***

**líquido, por favor, notar que las roscas están hacia la izquierda.**

### Inspección y Prueba:

Antes de mantener el gas a presión en las tuberías, cerrar todas la aberturas por donde pueda escapar el gas. Inmediatamente después de encender el gas, debe revisarse el sistema en busca de fugas. Esto puede hacerse observando el indicador de prueba de ½ pie cúbico y esperando 5 minutos para observar cualquier movimiento, o aplicando una solución de jabón a cada conexión de la tubería y observando las burbujas. Si se detectan fugas, hacer las reparaciones necesarias y repetir la prueba anterior.

Las tuberías y accesorios defectuosos deben ser cambiados, no deben ser reparados. Nunca usar ningún tipo de llama o fuego para localizar fugas de gas, usar una solución de jabón.

Luego que la tubería y el medidor han sido revisados completamente, purgar el aire del sistema. **NO** purgar el aire dentro de un ambiente cerrado.

La lavadora a presión y la válvula individual de cierre deben ser desconectados del sistema de tuberías de suministro de gas durante la prueba de presión donde una presión sobre ½ psig podría dañar la válvula de gas.

### Válvula de Cierre:

Se ha instalado una válvula de cierre entre la línea de suministro de gas y la lavadora. La instalación también incluye una unión entre la válvula de cierre y el quemador.

### Condensación en los Serpentes:

Cuando se bombea agua fría por los serpentines del calentador y los quemadores están encendidos, se producirá condensación sobre los serpentines y goteará al compartimiento del quemador dando la impresión de fugas en los serpentines, particularmente en días húmedos y fríos.

### Revisar el Serpentin del Calentador de Agua en busca de Fugas:

Con el quemador "APAGADO" arrancar la unidad de bombeo y dejar que funcione por unos minutos. Observar el compartimiento del quemador con una lámpara o una linterna de mano. Si no se observa ninguna fuga, el goteo de agua del serpentin será

producto de la condensación de gases combustibles cuando el quemador está encendido, como se ha descrito en el párrafo anterior.

### Instrucciones Para El Encendido



**ADVERTENCIA: El incumplimiento de las instrucciones podría resultar en incendio o explosión causando daños a la propiedad, accidentes personales o fatales.**

1. El equipo tiene un piloto que puede ser encendido en forma manual. Al encender el piloto, seguir éstas instrucciones en forma estricta.
2. **ANTES DE ENCENDER** revisar alrededor del equipo para detectar posible olor a gas. Revisar al nivel del piso ya que el gas propano es más pesado que el aire y se acumula sobre el piso.
 

**Para su seguridad: "¿Qué hacer si se detecta olor a gas?"**

  - a. No tratar de encender ningún equipo.
  - b. No tocar ningún interruptor eléctrico; no usar ningún teléfono del edificio.
  - c. Llamar inmediatamente a su proveedor de gas usando un teléfono del vecindario. Seguir las instrucciones de su proveedor de gas.
  - d. Si no se puede ubicar a su proveedor de gas, llamar al departamento de bomberos.
3. Usar solamente la mano para presionar o girar la perilla de control del gas. Nunca usar herramientas. Si no se puede presionar o girar la perilla con la mano, no tratar de repararla, llamar a un técnico de servicio calificado. El uso de fuerza durante la reparación podría resultar en incendio o explosión.
4. No usar la máquina cuando una de sus partes ha estado sumergida en agua. Llamar inmediatamente a un técnico de servicio calificado para revisar la máquina y reemplazar cualquier parte del sistema de control o de control de gas que ha estado sumergida en agua.

### Instrucciones De Operacion

1. **ALTO!** Leer cuidadosamente el manual del operador antes de operar esta máquina. El incumplimiento de las instrucciones y advertencias puede causar una operación defectuosa de la unidad y puede causar heridas serias y/o daños a la propiedad.
2. Apagar todos los interruptores.
3. Retirar y colocar el Tanque de propano líquido de la máquina tan lejos como lo permita la manguera de suministro.
4. Conectar la manguera de suministro de agua y abrir el agua. Accionar el gatillo de la pistola de rociado y dejar fluir agua hasta descargar todo el aire del sistema. Revisar si hay fugas de agua y ajustar según sea necesario.
5. Conectar el cable de energía a la conexión eléctrica apropiada de acuerdo a la información de la placa de serie. Presionar el botón de reajuste GFCI. El voltímetro VHP2-15021 D requiere un receptáculo de 20 amp para cumplir con la certificación UL.
6. Abrir la válvula del Tanque de propano líquido, luego presionar ligeramente la perilla de la válvula del control principal de gas que está sobre el costado derecho de la máquina y girar en dirección opuesta las agujas del reloj a la posición Piloto. **NOTA:** la perilla no puede ser girada de "Piloto" a "APAGADO" a menos que sea presionada ligeramente.
7. Presionar la perilla de control completamente y mantenerla en esa posición. Después de cinco (5) segundos, presionar el encendedor rojo hasta escuchar un sonido fuerte. Repetir este paso 3 ó 4 veces, si fuera necesario, hasta encender el piloto. Si el piloto no enciende, repetir la operación permitiendo un período de tiempo más largo antes de soltar la perilla de la válvula de gas. Después que el piloto encienda, continuar manteniendo la perilla de control hacia abajo aproximadamente por un (1) minuto antes de soltarla. Observar la mirilla del piloto en la parte posterior de la máquina.
8. Girar la perilla de control de gas en el sentido opuesto a las agujas del reloj hasta el punto de "ENCENDIDO."

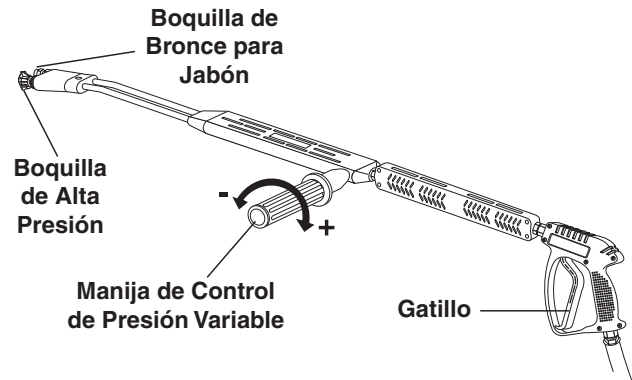

9. Para operar con agua fría, girar el interruptor a la posición de la bomba y accionar el gatillo de la pistola de rociado.
  - Asegure la boquilla de alta presión en el extremo de la varilla.
  - Gire la manilla para ajustar la presión.
  - Para aplicar detergente debe usarse baja presión.
  - Lea el manual para operar, previamente.
10. Para operar con agua caliente, girar el interruptor a la posición del quemador y accionar el gatillo de la pistola de rociado.
11. Para aplicar detergente, leer las instrucciones sobre el uso del inyector detergente.
12. **Para Detener:** limpiar las líneas de productos detergentes con agua fresca, cambiar a la posición de la bomba y continuar rociando agua hasta enfriar el quemador.
13. Después que el agua se ha enfriado, apagar la bomba. Apagar la llave principal de gas, luego cerrar la válvula del Tanque de propano líquido. Revisar que el Tanque de propano líquido esté fijo a la máquina cuando ésta sea transportada.
14. Cerrar el agua. Para protección contra el congelamiento, accionar el gatillo de la pistola de rociado para drenar el agua del sistema.

### Para Usar Vapor:

(Modelo VHP3-70021D solamente)

1. Girar la perilla del control en descargador en el sentido opuesto a las agujas del reloj. Esto reduce el fluir del agua por el serpentín.
2. La presión del agua disminuirá aproximadamente a 250 psi y la temperatura aumentará aproximadamente 250° F.
3. Después de usar vapor, girar la perilla del control en el descargador en el sentido de las agujas del

reloj hasta que pare. Bajará la temperatura. Antes de apagar la lavadora, dejar que funcione sin prender el quemador para enfriar el serpentín.

## Mantenimiento Y Servicio

### Mantenimiento Preventivo

1. Revisar si la bomba de agua está lubricada apropiadamente.
2. Seguir las instrucciones para acondicionamiento de invierno y prevenir daños por congelamiento de la bomba y los serpentines.
3. Siempre neutralizar y limpiar después de usar productos detergentes en el sistema.
4. Si el agua tiene alto contenido de minerales, usar un ablandador de agua o eliminador de escamas en el sistema, según sea necesario.
5. No permitir que líquidos ácidos, caústicos o abrasivos sean bombeados a través del sistema.
6. Siempre usar productos de limpieza de alta calidad.
7. Nunca hacer funcionar la bomba en seco por extensos períodos de tiempo.
8. Periódicamente, limpiar los depósitos de cal de los serpentines según las instrucciones.

Se aconseja inspeccionar regularmente, el quemador en forma visual. Revisar el ingreso de aire para asegurar que no esté atascado o bloqueado. Limpiar todos los derrames de aceite y mantener la máquina limpia y seca.

Las áreas alrededor de la lavadora deberán mantenerse limpias y libres de materiales combustibles, gasolina y otros líquidos inflamables.

El flujo de combustión y aire de ventilación al quemador no deben ser obstruidos o bloqueados de ninguna manera.

## Mantenimiento Y Servicio

### Válvulas de Descarga:

Las válvulas de descarga liberan la presión en la línea cuando la pistola de rociado está cerrada. La válvulas de descarga son programadas y verificadas antes de salir de fábrica. Ocasionalmente, deben regularse para mantener la presión correcta. (Ver la sección del manual sobre válvulas de descarga para el procedimiento correcto de regulación de la válvula.)

## Procedimiento de Acondicionamiento para el Invierno:

El daño debido al congelamiento no está cubierto por la garantía. Respetar los siguientes procedimientos para el clima frío siempre que la lavadora deba almacenarse u operarse a la intemperie bajo condiciones de congelamiento.

Durante los meses de invierno, cuando la temperatura baja a menos de 32° F, se debe proteger la máquina del congelamiento según sea necesario. Almacenar la máquina en un ambiente con calefacción. Si esto no es posible, mezclar una solución 50/50 de anticongelante/ agua en un depósito de 5 galones. Colocar una sección corta de manguera de jardín en el depósito y conectar a la máquina. Elevar el depósito y prender la bomba para sifonear el anticongelante a la máquina. Si se dispone de aire comprimido, puede instalarse un accesorio de aire al conector de entrada y todo el agua será evacuada fuera del sistema.

## Termostato de Control de Agua Caliente:

Para seguridad, cada unidad está equipada con un interruptor de control de temperatura. Si la temperatura del agua excede la temperatura de operación, el control apagará el quemador hasta que el agua se enfríe.

## Bombas:

Usar solamente aceite no-detergente SAE 10W-40. Cambiar el aceite después de las primeras 50 horas de uso. Luego, cambiar el aceite cada tres meses o en intervalos de 500 horas. El nivel de aceite debe ser revisado usando la varilla de medir ubicada en la bomba o el punto rojo visible a través de la ventana del calibrador. El aceite debe mantenerse en ese nivel.

## Limpieza de Serpentines:

En áreas de agua alcalina, los depósitos de cal pueden acumularse en los serpentines rápidamente. Estos depósitos se incrementarán con la alta temperatura generada en los serpentines. La mejor prevención para la sedimentación es usar productos de limpieza de alta calidad. En áreas donde el agua alcalina es un problema, el uso regular de Polvo eliminador de cal (parte #9-028008) limpiará la cal y otros sedimentos antes que obstruyan el serpentín.

### **Eliminador de cal de Serpentes:**

Se recomienda un lavado periódico de los serpentines.

1. Llenar un depósito con 4 galones de agua y luego añadir 1 libra de polvo desincrustante. Mezclar completamente.
2. Retirar la varilla de la pistola y colocar la pistola en un depósito. Asegurar que el gatillo de la pistola esté en posición abierta.
3. Unir una sección corta (3-5 pies) de manguera de jardín a la máquina para sifonear la solución hacia un depósito elevado. Encender la bomba para que la solución sea bombeada a través de los serpentines de regreso al depósito. La solución deberá circular por 2-4 horas.
4. Después de hacer circular la solución, lavar todo el sistema con agua fresca. Reinstalar la varilla en la pistola.

### **Remoción de Hollín del Serpentin de Calentamiento:**

Durante el proceso de calentamiento pueden producirse residuos de combustible en forma de hollín entre los serpentines de calentamiento, bloquear el flujo de aire y afectar la combustión del quemador. Cuando se observe hollín, debe limpiarse después de seguir los pasos para desmontar el serpentín.

1. Retirar el ensamble del tanque destornillando los tres tornillos Tek y levantando el cabezal del tanque.
2. Retirar los dos niples de la tubería y los accesorios correspondientes.
3. Levantar el serpentín fuera de la envoltura exterior.

**PRECAUCION: El serpentín pesa casi 80 libras. Usar técnicas de levantamiento apropiadas.**

4. Limpiar, reparar y reemplazar el serpentín siguiendo los pasos anteriores pero a la inversa.

### **Válvula de Alivio de Presión:**

Cada unidad está equipada con una válvula de alivio de presión para descargar la presión del sistema cuando se detectan presiones de operación más altas de lo normal. Las altas presiones inusitadas provienen de algún objeto que obstruye la boquilla de rociado. Este problema se puede remediar fácilmente al retirar la obstrucción. Si la presión de operación de la unidad es normal y la válvula de alivio sigue con fugas, reparar o reemplazar la válvula.

### **Capacidad del Cilindro de Gas Propano:**

Una importante consideración con los sistemas de gas propano, es la capacidad del cilindro de suministro en relación a las necesidades del quemador. El quemador opera con gas propano del cilindro, el líquido del cilindro ebulle para mantener la presión del gas. Este proceso de ebullición enfría el líquido y, en una situación de demanda continua y exigente, la temperatura del líquido puede disminuir a un punto que no puede suministrar gas tan rápido como se requiere. En este caso, podría ser necesario calentar el Cilindro de Gas Propano rociando agua caliente que no exceda 120° F, sobre el cilindro frío o al colocar dos botellas de gas propano juntas para incrementar la capacidad total de vaporización. Se recomienda usar una botella de gas propano de 30 libras de capacidad en la unidad.

## Uso del Inyector de Productos Detergentes

**ADVERTENCIA:** *Algunos productos detergentes pueden ser dañinos cuando se los inhala o ingiere, causar náuseas, desmayo o envenenamiento agudo. Los elementos dañinos pueden causar daño a la propiedad o lesiones graves.*

El conjunto de inyector para productos detergentes de se puede utilizar para hacer sifón y mezclar los detergentes.

1. Apague el motor y cierre la entrada de agua. Antes de acoplar el inyector de productos detergentes, abra la pistola de rociado para aliviar la presión.
2. Para acoplar el inyector de productos detergentes entre la unidad de lavado a presión y la manguera de alta presión, tire del cuello del acoplador de conexión rápida del inyector hacia atrás y coloque el manguito de unión de descarga. La flecha de la válvula de inyección debe apuntar en la dirección del flujo.
3. Conecte la manguera de descarga de presión al manguito de unión de inyección con el acoplador de conexión rápida. Empuje el cuello del acoplador hacia el manguito de unión.
4. Haga arrancar la unidad tal como se describe en las Instrucciones para operar la unidad.
5. Coloque el tubo de aspiración para el producto detergente en el recipiente de la solución detergente.
6. Instale la boquilla para detergente en el acople rápido.
7. Abra la pistola a gatillo. La proporción de agua y del producto detergente es de aproximadamente 15 a 1.
8. Para limpiar, coloque el tubo para el producto detergente en un recipiente con agua limpia y siga los pasos 5 y 7 para evitar que los depósitos detergentes dañen el inyector.
9. Si la unidad cuenta con una extensión de presión variable; para limpiar, alivie la presión haciendo girar la manija para el control de presión en sentido contrario a las agujas del reloj. Esto dirige el flujo de agua a través de la boquilla de jabón y permite que el inyector del producto detergente succione el jabón. Para enjuagar con agua a alta presión, simplemente gire la manija de control en la dirección de las agujas del reloj.

**NOTA:** El inyector para los productos detergentes no puede hacer sifón cuando la manija de control, de la extensión de presión variable, se encuentra en posición de alta presión.

## Identificación de Componentes

